



nectre

WOOD FIRE RANGE



nectre.com.au

Nectre FORM 1



Displayed: PEDESTAL
Size: 300(w) x 550(d) x 600(h)mm



A fresh and novel take on what a combustion heater can look like, and the only wood heater in the Australian wood heating landscape with its narrow yet deep form factor. The sleek capsule shape is resolved with cast iron, high quality stainless steel controls and curved glass, which offers a wider view of the flames, impressive performance and heating efficiency.

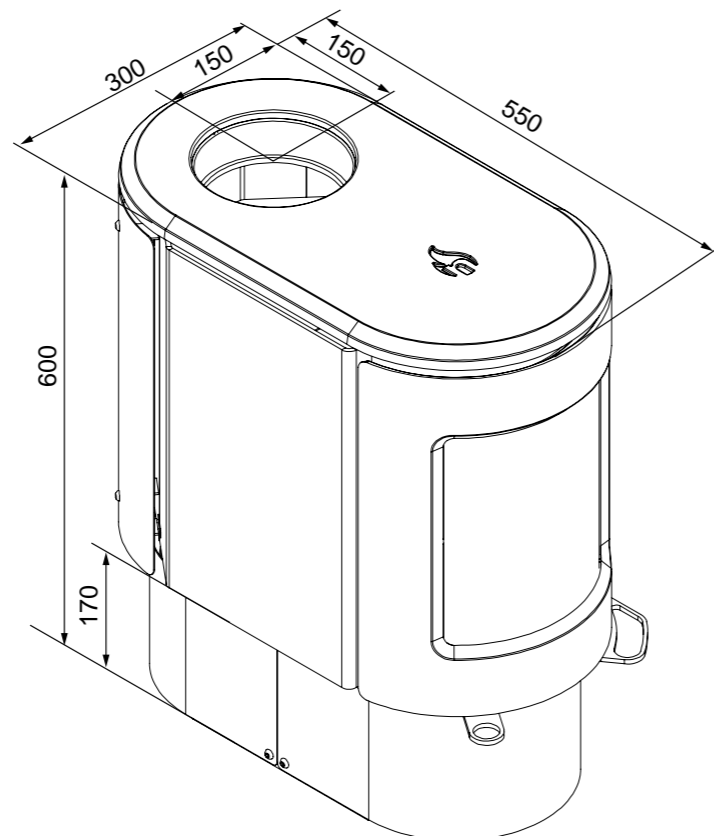

SPECIFICATIONS

Coverage	Up to 90m ²
Heat Output	Max ave. 7kW
Efficiency	70%
Emissions	0.70g/kg
Firebox size	235(w) x 365(d) x 270(h)mm
Dimensions	300(w) x 550(d) x 600(h)mm
Max log width	340mm
Heater Weight	80kg
Heating style	Radiant



*All dimensions are in millimeters (mm) unless specified otherwise and are shown without side shields fitted (if available). In the interest of product development, Glen Dimplex Australia Pty Ltd reserve the right to change product specifications without prior notice. Refer to the IOM online for the latest up to date information.

Nectre FORM 2



Displayed: WOODSTACKER
Size: 520(w) x 465(d) x 1103(h)mm



Designed to suit the modern Australian home, it is not only clean and extremely modern in its aesthetics but performs exceptionally well with low emissions and powerful heat output. The ability to connect the air intake of the heater to an outside air source, will mean that it can efficiently heat the modern Australian home. A cast iron door and top plate not only resonate the robust quality synonymous with the Nectre brand but also more effectively radiate heat into the home. A large pane of curved, flame-resistant glass gives a more captivating view of the fire.

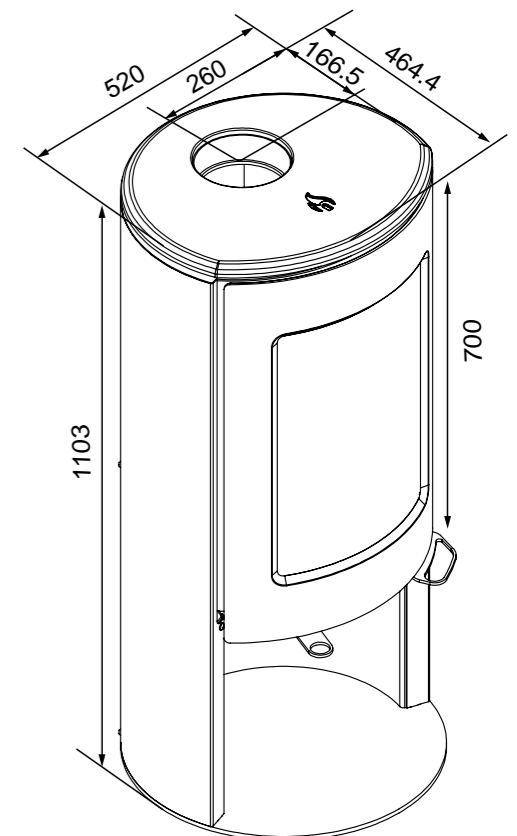

SPECIFICATIONS

Coverage	Up to 180m ²
Heat Output	Max ave. 13kW
Efficiency	65%
Emissions	0.60g/kg
Firebox size	335(w) x 295(d) x 365(h)mm
Dimensions	520(w) x 464.4(d) x 1103(h)mm
Max log width	330mm
Heater Weight	146kg
Heating style	Convection



*All dimensions are in millimeters (mm) unless specified otherwise and are shown without side shields fitted (if available). In the interest of product development, Glen Dimplex Australia Pty Ltd reserve the right to change product specifications without prior notice. Refer to the IOM online for the latest up to date information.

Nectre N15



Displayed: WOODSTACKER
Size: 462(w) x 553(d) x 968(h)mm

Nectre N60



Displayed: CURVE SIDE
Size: 581(w) x 510(d) x 1041(h)mm

If you don't have much space to play with – don't worry. The Nectre N15 is simple, classic and compact, but offers an impressive radiant heating capacity of up to 160m². Available in three variants, the Nectre N15 is the perfect choice for adding some wood fired magic to any corner of the room. Grab a book and get cosy.

SPECIFICATIONS

Coverage	Up to 160m ²	Firebox size	370(w) x 320(d) x 320(h)mm
Heat Output	Max ave. 13kW	Dimensions	Legs 462(w) x 553(d) x 728(h)mm Wood Stacker 462(w) x 553(d) x 968(h)mm Pedestal 462(w) x 553(d) x 791(h)mm
Efficiency	79%	Heater Weight	Legs 102kg Wood Stacker 131kg Pedestal 108kg
Emissions	1.3g/kg		
Max log width	330mm		
Heating style	Radiant		

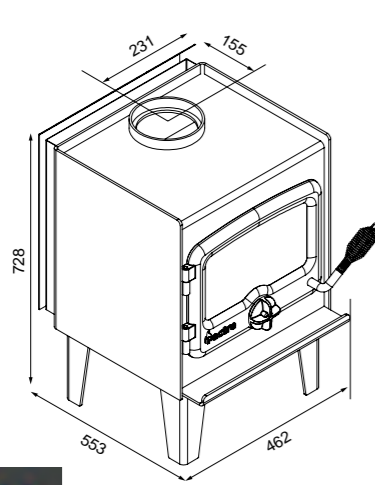

Legs

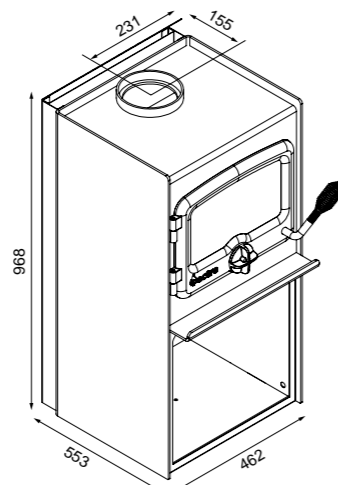

Wood Stacker

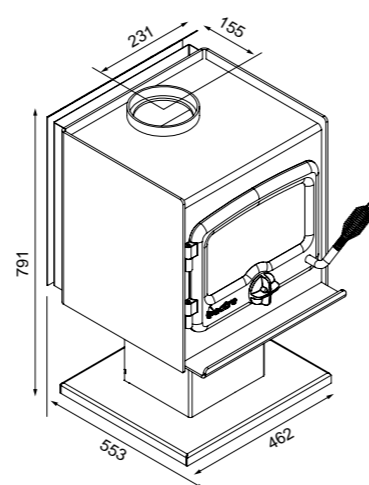

Pedestal



*All dimensions are in millimeters (mm) unless specified otherwise and are shown without side shields fitted (if available). In the interest of product development, Glen Dimplex Australia Pty Ltd reserve the right to change product specifications without prior notice. Refer to the IOM online for the latest up to date information.

The Nectre N60 combines low emissions and high efficiency with great looks and easy to use functions, making it an easy favourite. It's minimal design fits beautifully in either traditional or contemporary living areas.

SPECIFICATIONS

Coverage	Up to 170m ²
Heat Output	Max ave. 11kW
Efficiency	73%
Emissions	0.60g/kg
Firebox size	345(w) x 275(d) x 450(h)mm
Dimensions	Curved 581(w) x 510(d) x 1041(h)mm Naked 454(w) x 508(d) x 1041(h)mm
Max log width	300mm
Heater Weight	Curved 188kg Naked 178kg
Heating style	Radiant/ Convection

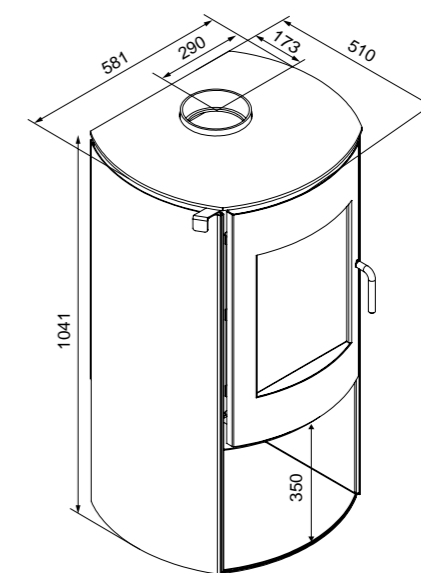

Curved

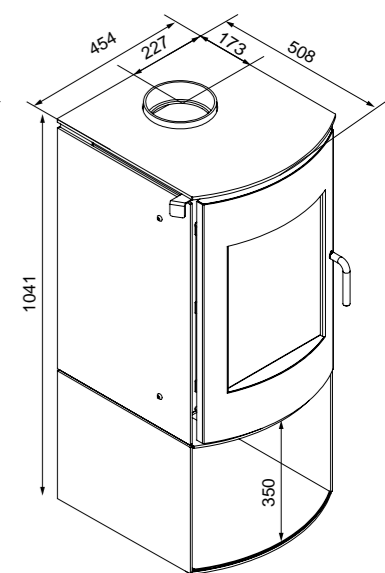

Naked



*All dimensions are in millimeters (mm) unless specified otherwise and are shown without side shields fitted (if available). In the interest of product development, Glen Dimplex Australia Pty Ltd reserve the right to change product specifications without prior notice. Refer to the IOM online for the latest up to date information.

Nectre MK1



Displayed: LEGS
Size: 725(w) x 541(d) x 729(h)mm

Nectre MK2



Displayed: PEDESTAL
Size: 750(w) x 560(d) x 744(h)mm

A powerful and robust radiant fireplace, the Nectre Mk1 is a popular choice with a classic design that works well in both traditional and modern settings. For someone who wants to add timeless charm to a contemporary space or simply be captivated by the rustic look, the Mk1 and its impressive heating performance make it a standout.

SPECIFICATIONS

Coverage	Up to 200m ²
Heat Output	Max ave. 19kW
Efficiency	73%
Emissions	0.95g/kg
Firebox size	580(w) x 315(d) x 340(h)mm
Dimensions	Legs 725(w) x 541(d) x 729(h)mm Pedestal 725(w) x 541(d) x 762(h)mm
Max log width	500mm
Heater Weight	Legs 134kg Pedestal 143kg
Heating style	Radiant

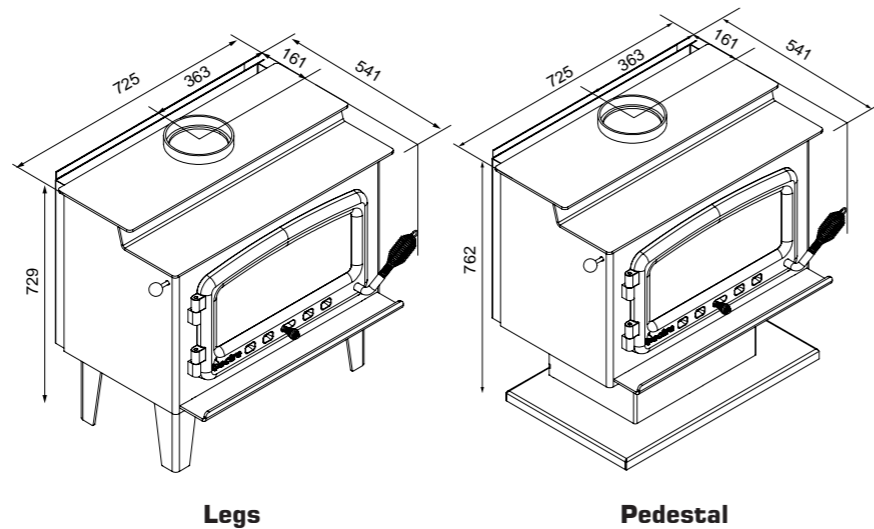

The Nectre Mk2 is a simple and elegant radiant/convective wood heater, powerful enough to heat around 185m² of living area. Mk2's convective design allows more flexible placement in the home compared to pure radiant wood heaters. Available with either legs or pedestal base and optional fan (pedestal base only), your Mk2 fireplace can perfectly complement your space and design tastes.

SPECIFICATIONS

Coverage	Up to 200m ²
Heat Output	Max ave. 18kW
Efficiency	73%
Emissions	0.80g/kg - without fan
Firebox size	515(w) x 305(d) x 330(h)mm
Dimensions	Legs 750(w) x 560(d) x 681(h)mm Pedestal 750(w) x 560(d) x 744(h)mm
Max log width	450mm
Heater Weight	Legs 163kg Pedestal 177kg
Heating style	Radiant/ Convection

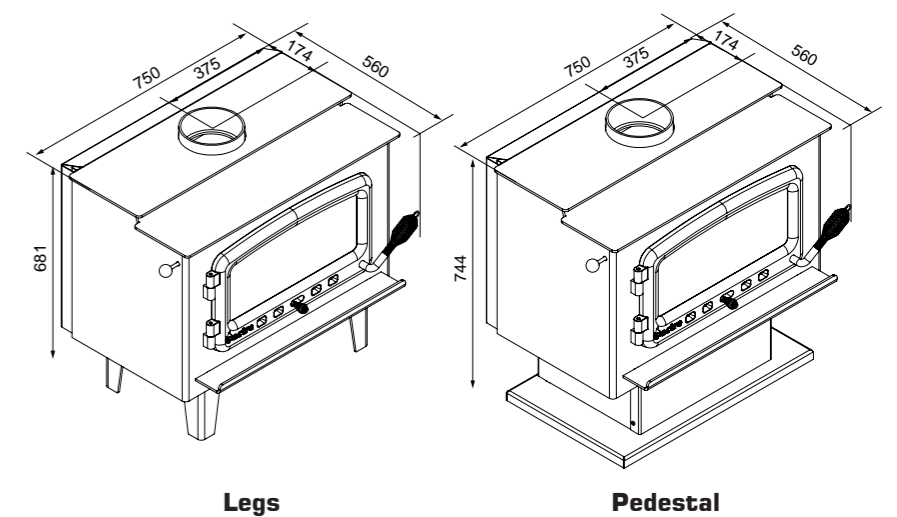

*Optional 3 speed fan for pedestal only



*All dimensions are in millimeters (mm) unless specified otherwise and are shown without side shields fitted (if available). In the interest of product development, Glen Dimplex Australia Pty Ltd reserve the right to change product specifications without prior notice. Refer to the IOM online for the latest up to date information.



*All dimensions are in millimeters (mm) unless specified otherwise and are shown without side shields fitted (if available). In the interest of product development, Glen Dimplex Australia Pty Ltd reserve the right to change product specifications without prior notice. Refer to the IOM online for the latest up to date information.

Nectre MK3



Displayed: WOODSTACKER
Size: 750(w) x 659(d) x 820(h)mm

The Nectre Mk3 is a strong performer, combining its timeless design and powerful radiant/convective heat output with the practicality of built-in firewood storage. With a deeper firebox than our Mk1 or Mk2 models, and featuring a remote controlled 3-speed fan, the Mk3 does it all.

SPECIFICATIONS

Coverage	Up to 270m ²
Heat Output	Max ave. 18kW
Efficiency	62%
Emissions	1.1g/kg
Firebox size	530(w) x 400(d) x 330(h)mm
Dimensions	750(w) x 658.5(d) x 820(h)mm
Max log width	540mm
Heater Weight	160kg
Heating style	Radiant / Convection

*3 speed remote control fan comes as standard

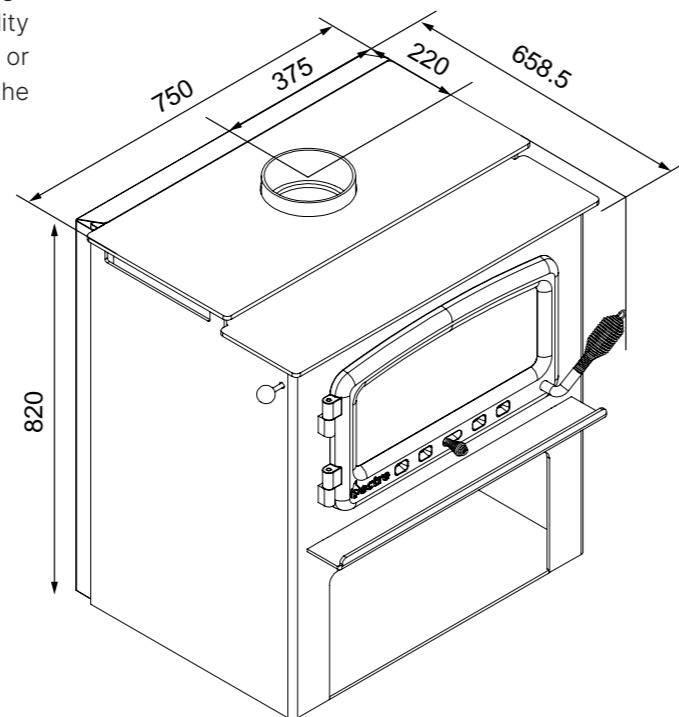

BurnWise
A member of The Burnwise Group

*All dimensions are in millimeters (mm) unless specified otherwise and are shown without side shields fitted (if available). In the interest of product development, Glen Dimplex Australia Pty Ltd reserve the right to change product specifications without prior notice. Refer to the IOM online for the latest up to date information.

Nectre MEGA



Displayed: PEDESTAL
Size: 760(w) x 663(d) x 838 (h)mm

The highest output heater in the Nectre range - the MEGA is designed to heat larger living spaces through its utilisation of both convection and radiant heating, giving you the best of both worlds.

SPECIFICATIONS

Coverage	Up to 340m ²
Heat Output	Max ave. 18kW
Efficiency	62%
Emissions	1.5g/kg
Firebox size	600(w) x 430(d) x 320(h)
Dimensions	Legs 760(w) x 663(d) x 834(h)mm Pedestal 760(w) x 663(d) x 838(h)mm
Max log width	500mm
Heater Weight	Legs 249kg Pedestal 262kg Pedestal with Fan 263kg
Heating style	Radiant / Convection

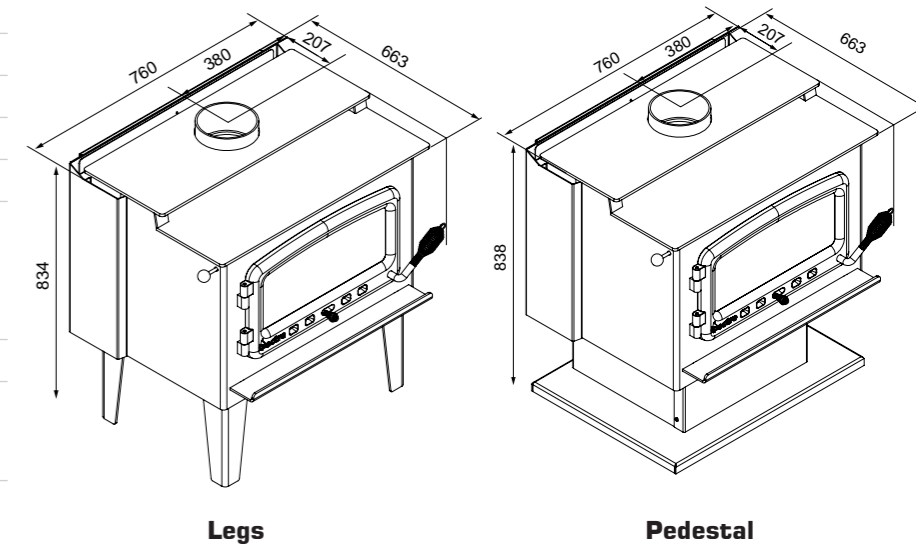

Legs

Pedestal

BurnWise
A member of The Burnwise Group

*Optional 3 speed fan for pedestal model only

*All dimensions are in millimeters (mm) unless specified otherwise and are shown without side shields fitted (if available). In the interest of product development, Glen Dimplex Australia Pty Ltd reserve the right to change product specifications without prior notice. Refer to the IOM online for the latest up to date information.

Nectre INBUILT

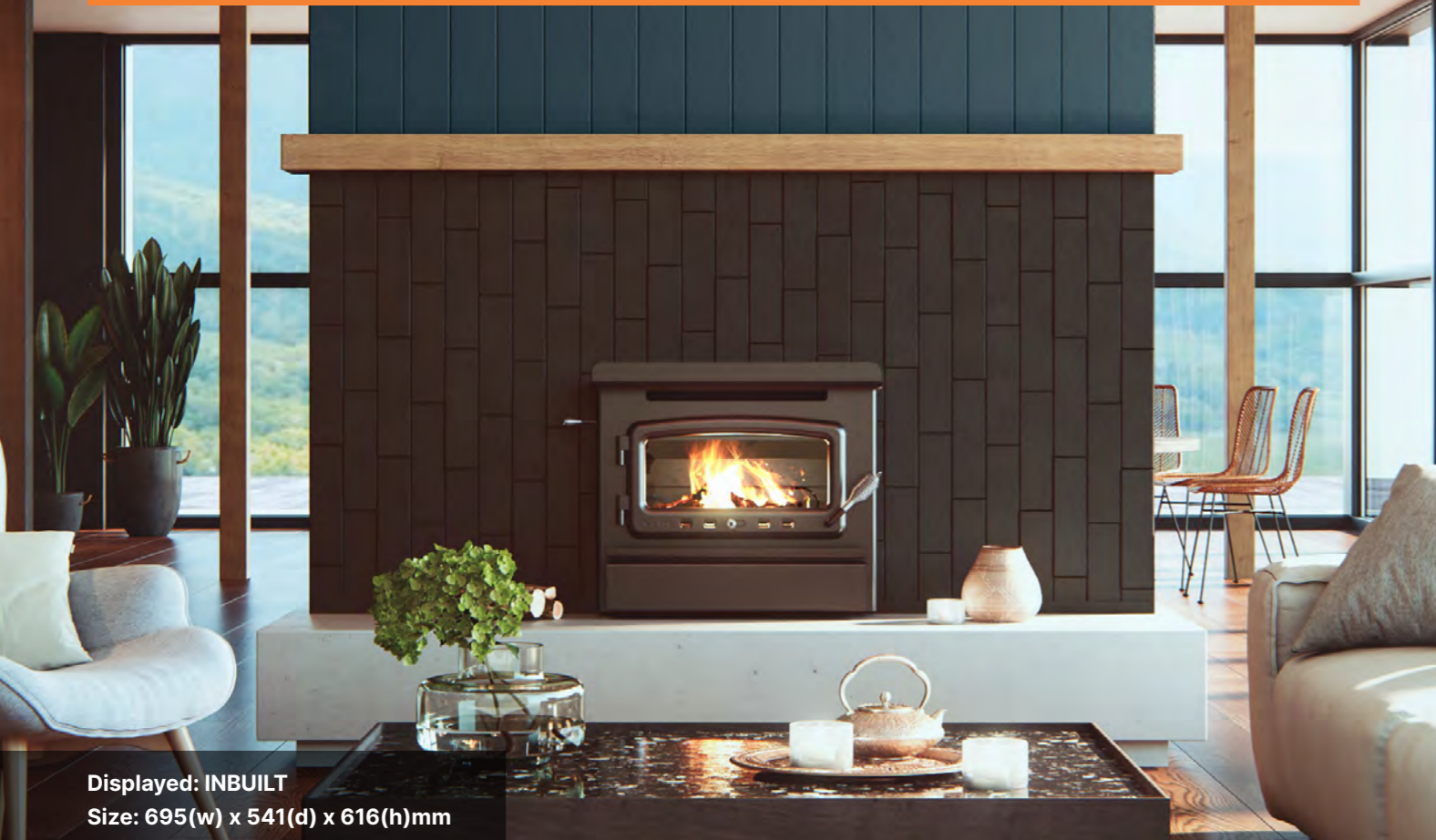

Displayed: INBUILT
Size: 695(w) x 541(d) x 616(h)mm

The Nectre Inbuilt is the ideal solution for most masonry fireplaces. It will turn your fireplace into a low emission, effective heating source, all the while retaining the charm that can only be achieved through a wood fire. Featuring a remote controlled three-speed fan, the Inbuilt will deliver all the warmth and charm you expect from a Nectre.

SPECIFICATIONS

Coverage	Up to 160m ²
Heat Output	Max ave. 10kW
Efficiency	62%
Emissions	0.90g/kg
Firebox size	500(w) x 325(d) x 370(h)mm
Dimensions	695(w) x 541(d) x 616(h)mm
Cavity Space	568.2(w) x 331.1(d) x 578.2(h)mm
Max log width	430mm
Heater Weight	169kg
Heating style	Radiant / Convection

*3 speed remote control fan comes as standard

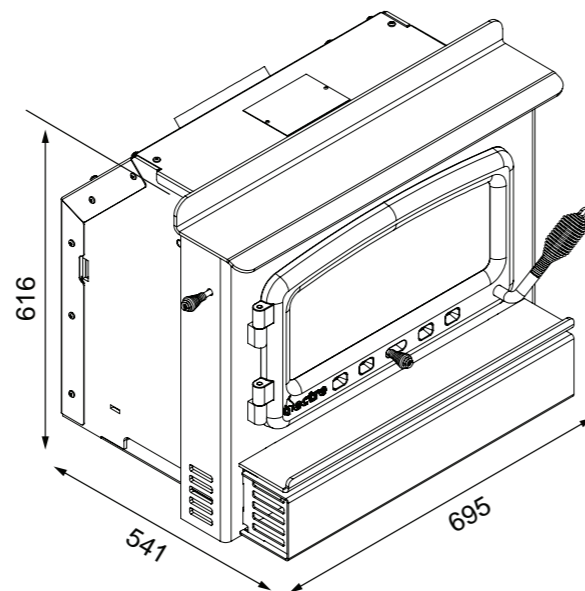

BurnWise
An Australian Wood Heating Specialist

*All dimensions are in millimeters (mm) unless specified otherwise and are shown without side shields fitted (if available). In the interest of product development, Glen Dimplex Australia Pty Ltd reserve the right to change product specifications without prior notice. Refer to the IOM online for the latest up to date information.

Nectre BAKERS OVEN

Why stop at just heating your home? The Nectre Bakers Oven gives you the option to warm your living area and cook meals with the efficiency and natural power of a real wood fire. With a small footprint and its traditional styled stove top and large oven, imagine impressing your guests in a cosy corner of your home with the sights and smells of home cooking while watching logs smoulder and flames dance.

SPECIFICATIONS

Coverage	Up to 120m ²
Heat Output	Up to 11kW
Firebox size	340(w) x 300(d) x 380(h)mm
Dimensions	550(w) x 652(d) x 866(h)mm
Max log width	300mm
Heater Weight	166kg
Heating style	Radiant

*Optional factory fitted domestic hot water booster

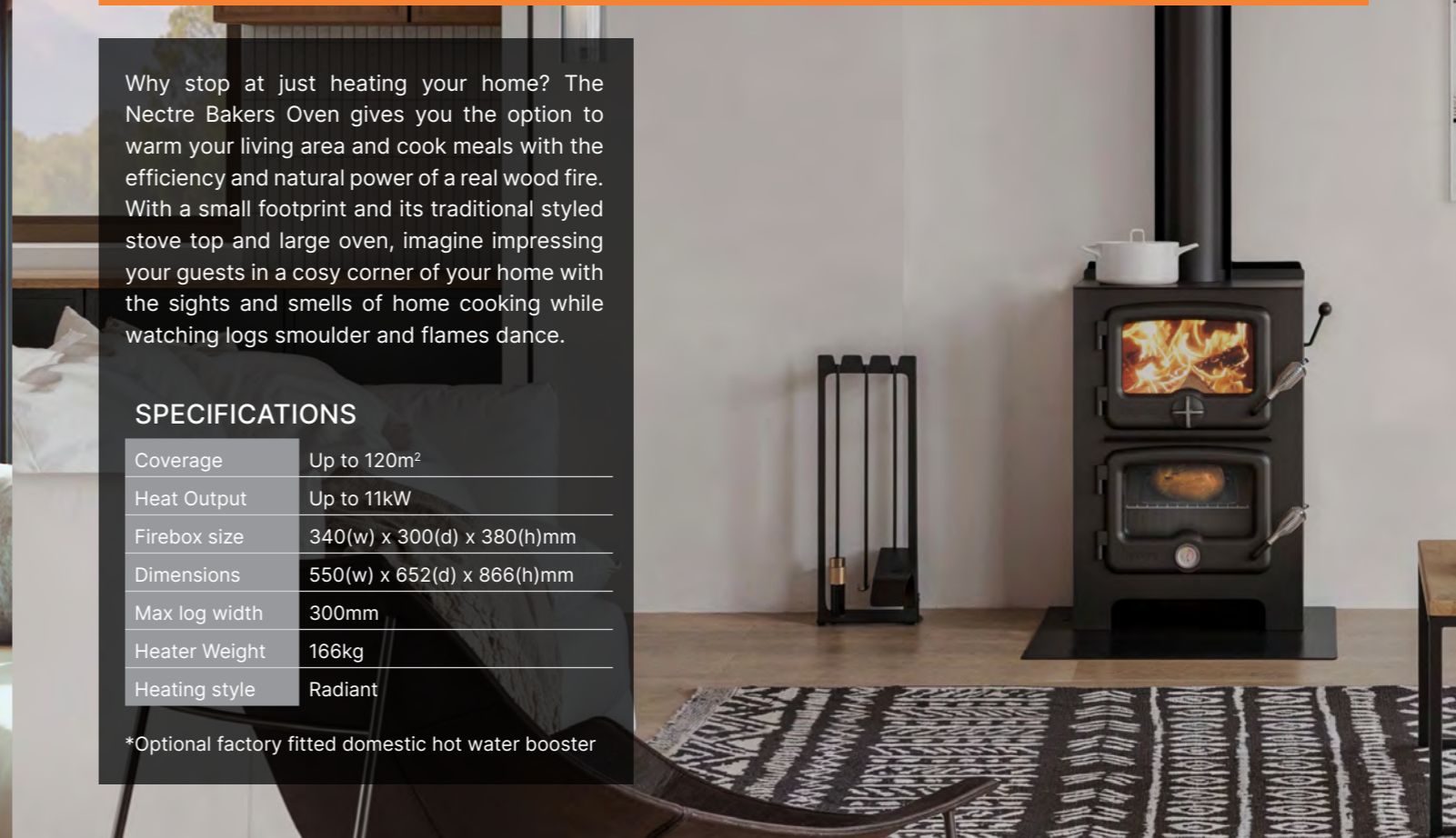

Nectre BIG BAKERS OVEN

The Nectre Big Bakers Oven offers all the familiar features of its smaller sibling and then some. Its larger footprint affords a more spacious oven and cooktop, perfect for feeding a larger crowd. The upgraded size of the Big Bakers Oven pairs perfectly with the inherent character and charm that Nectre is known for.

SPECIFICATIONS

Coverage	Up to 200m ²
Heat Output	Up to 14kW
Firebox size	485(w) x 295(d) x 300(h)mm
Dimensions	690(w) x 654(d) x 865(h)mm
Max log width	445mm
Heater Weight	231kg
Heating style	Radiant

*Optional factory fitted domestic hot water booster



How to Choose a Wood Heater?

Taking the time to understand how a wood heater works and your heating requirements.

Find the best type of wood heater for you. There are two basic types of wood heaters in Australia, radiant and convection.

Work out the size and space you require to heat. Measure the size of the room or rooms as well as the height of the ceilings.

Find out the level of insulation in your house. Modern houses will have wall and roof insulation, making them more efficient.

Window glazing and furnishings are important to know to understand how much heat is lost in the house.

The layout of your home will have a direct impact on the selecting the best heater for you. The location of the heater and the number of levels in the home are also vital.

Get the correct sized unit for your house. Units that are too small or too large will be inefficient and possibly dangerous to operate.

The geographic location of your house is also important. Different areas of Australia require different heating needs.

RADIANT HEATERS (Nectre Form 1, Mk1 & N15)

A radiant heater does not have any outer casings on the firebox except for a rear heatshield. A radiant heater will heat the objects in the room in a straight line from the heater, like an electric bar radiator. Radiant heaters are ideal for rooms with high ceilings and used in conjunction with a ceiling fan is a very effective method of heating. A radiant heater will require a larger clearance to the sides than a convection style heater.

RADIANT / CONVECTION HEATER (Nectre Form 2, Mk2, Mk3, Mega, N60, & Inbuilt)

A radiant/convection heater will emit radiant heat from the unshielded portions of the firebox. The addition of convection chambers built into the sides and rear of the appliance will allow for natural convective heating, which can be boosted by the addition of an optional fan on selected models. Heaters with convection chambers will generally have smaller clearance requirements due to the firebox being shielded.

Maintaining a wood heater is easier than you think - have a read of our operating manuals for more information. Always remember that the best fuel is adequately seasoned (dry) wood, which will only improve your experience in maintaining your heater.

Nectre Flue Requirements

The flue system used when installing a Nectre must comply with the current installation standards of AS/NZS 2918. Full instructions on the installation of the flue will be supplied with the flue kit and these must be adhered to. The minimum exit height from the top of the floor protector (hearth) must not be less than 4.6m and the minimum exit height above the roof line of the roof ridge as detailed in the instructions.

SUITABLE FLUE SHIELD CONFIGURATION

- 

REAR SHIELD
900mm length, minimum 160° arc, stainless steel rear flue shield, can be painted black.
Models suitable for FORM 1 | FORM 2 | N15 | Mk1 | Mk2 | Mk3 | Mega | N60 | Bakers Ovens

- 

DECROMESH
Decromesh with 900mm inner reflector fitted with DLR
Models suitable for N15 | Mk1 | Mk2 | Mk3 | Mega | N60

Decromesh with no inner reflector fitted with DLR
Models suitable for FORM 1 | FORM 2

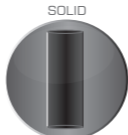
- 

SOLID
200mm Solid flue outer with 900mm inner reflector fitted with DLR
Model suitable for FORM 2 | N15 | Mk1 | Mk2 | Mk3 | Mega | N60

200mm Solid flue outer with no inner reflector fitted with DLR
Model suitable for FORM 1

- 

Decromesh Locating Ring (DLR) is supplied with all models where required

- 

4.6m Flue from the hearth plus the minimum above the roof line of the roof ridge.

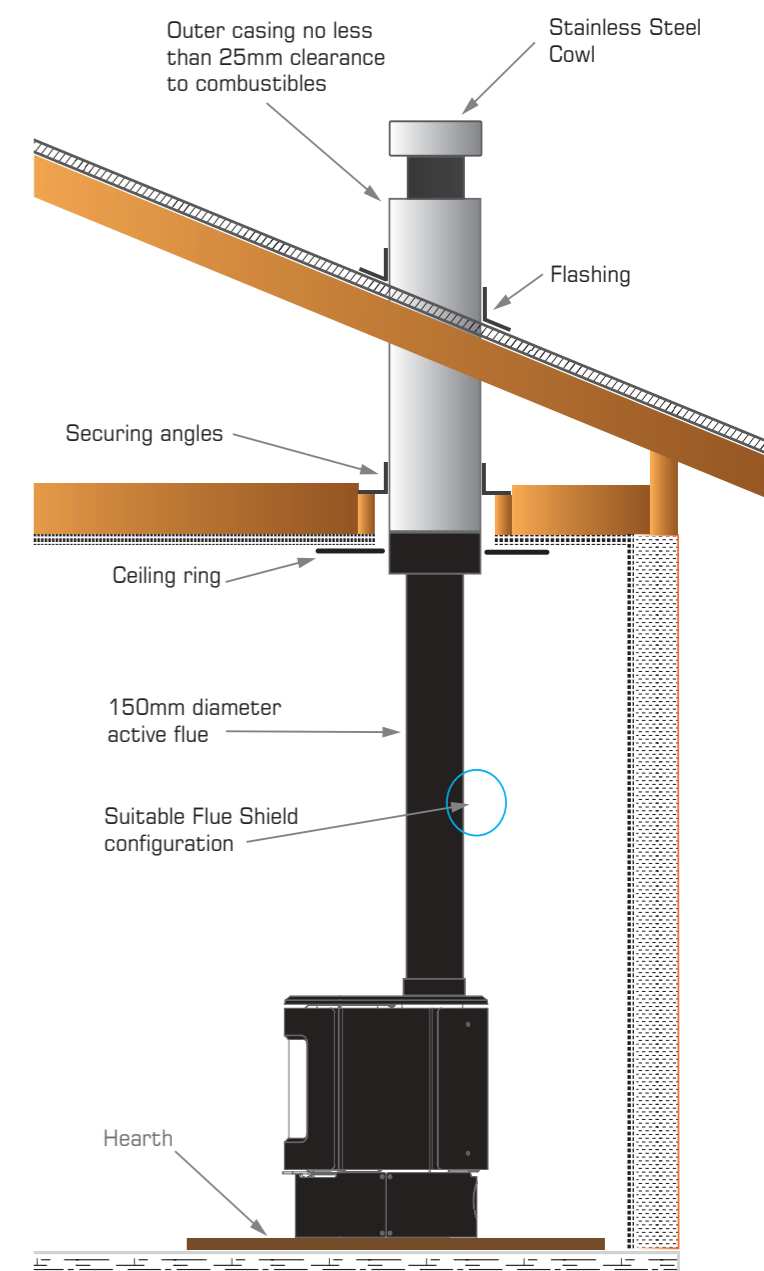

For the very best performance out of a Nectre wood heater, we recommend only burning dry seasoned hardwood. Pre-season maintenance check and a possible flue clean will ensure excellent Nectre performance. Avoid using salt borne drift wood, pine and/or chemically treated woods.



Nectre Product Reference Guide

		Form 1	Form 2	N15			N60		Mk1		
Type		Radiant	Convection	Radiant			Radiant / Convection		Radiant		
Style		Contemporary	Contemporary	Traditional			Contemporary		Traditional		
Base		Pedestal	Woodstacker	Legs	Woodstacker	Pedestal	Naked	Curved	Legs	Pedestal	
Colour		Black	Black	Black			Black		Black		
Tested with Fan		No	No	No			No		No		
Performance	Output (Kilowatts)	Peak	8.7	15.2	15			13		22	
		Ave.	7	13	13			11		19	
	Emissions	g/kg	0.70	0.60	1.3			0.60		0.95	
	Efficiency (%)	Peak	74	71.5	86			84		81	
		Ave.	70	65	79			73		73	
Coverage	squares	10	19	13-17			14-18		18-22		
	m ²	90	180	120-160			130-170		170-200		
Specification	Heater Size	kg	80	146	90	127	90	190	190	115	120
		(w)	300	520	462	462	462	454	581	725	725
		(d)	550	464.4	553	553	553	508	510	541	541
		(h)	600	1103	728	968	791	1041	1041	729	762
		Log Size (max)	mm	340	330	330			300		500
	Firebox size	m ³	0.023	0.036	0.038			0.043		0.062	
	Fabricated	Steel	4, 5 & 6	4, 5 & 6	6			6		6	
	Hearth (min)	(w)	594	725	900			720		900	
(d)		850	764.4	900			740		900		
Thickness		5	5	15			7.5		15		
Options	Fan (manual)	3 Speed									
	Fan (remote)	3 Speed									
	Shields	Side			Yes					Yes	
	Trivet	Cast			Yes						
	Air Connection	Outside	Yes	Yes							



Nectre Product Reference Guide

		Mk2	Mk3	MEGA		Inbuilt		Bakers Oven			
Type		Radiant / Convection		Radiant / Convection		Radiant / Convection		Radiant			
Style		Traditional		Traditional		Traditional		Traditional			
Base		Legs	Pedestal	Woodstacker		Legs	Pedestal	-	Original	BIG	
Colour		Black		Black		Black		Black			
Tested with Fan		No	Yes	Yes		No	Yes	Yes			
Performance	Output (Kilowatts)	Peak	20		21		20		25		
		Ave.	18		18		16		18		
	Emissions	g/kg	0.80	1.3	1.1		1.4		1.5		
	Efficiency (%)	Peak	67	79	66		65		65		
		Ave.	61	73	62		62		62		
Coverage	squares	18-22		24-28		30-37		13-17			
	m ²	170-200		240-270		280-340		120-160			
Specification	Heater Size	kg	140	160	160		170	180	120		
		(w)	750	750	750		760	760	695		
		(d)	560	560	658.5		663	663	541		
		(h)	681	744	820		834	838	616		
		Log Size (max)	mm	450		450		500		430	
	Firebox size	m ³	0.052		0.070		0.082		0.050		
	Fabricated	Steel	6		6 & 8		6 & 8		6		
	Hearth (min)	(w)	900		900		900		900		
(d)		900		900		900		400	300	900	900
Thickness		15		15		15		40	110	12	15
Options	Fan (manual)	3 Speed	Yes				Yes				
	Fan (remote)	3 Speed			Yes				Yes		
	Shields	Side									
	Trivet	Cast									



NOTE: Nectre Bakers Oven & Big Bakers Oven emissions and efficiency are shown as n/a, they are classified as a cooking stove and are exempt. All measurements are in millimeters (mm) and are correct at time of print. Glen Dimplex Australia Pty Ltd reserves the right to change or alter product specifications as required. Glen Dimplex Australia Pty Ltd reserves the right to change or alter drawings, specifications or dimensions without prior notice. The information contained within the document was correct at time of printing.

Established in 1980, the Nectre brand has long been recognised as a honest and reliable wood heater that produces stunning warmth and comfort from a timeless design with easy to operate features. Today, that Nectre warmth and comfort is enjoyed in well over 5 countries.

We are proud of our tradition, history and even more so to be one of the leading Australian wood heater manufacturers. We strive to make the very best heater for value while providing excellent all-round performance. We are driven daily to achieve manufacturing excellence and as such every Nectre wood heater meets or exceeds the requirements of AS/NZS 4012 and 4013 at the time of manufacture.

The famous Australian Made® logo is the true mark of Aussie authenticity and is Australia's most trusted, recognised and widely used country of origin symbol, underpinned by a third-party accreditation system, which ensures products that carry the logo are certified as 'genuinely Australian'.

Nectre heaters are designed and manufactured right here in Australia, delivering rock-solid build quality, exceptional heating performance and timeless classic design to all Australians.



“Heating Australian Homes with style”

Authorised Nectre Dealer



Glen Dimplex Australia Pty Ltd
8 Lakeview Drive,
Scoresby, VIC 3179
T 1300 554 155
E flame.care@glendimplex.com.au

Nectre is a registered trademark of
Glen Dimplex Australia Pty Ltd, all rights reserved.