

# NECTRE BOILERS

**ALL BOILER GRADE STAINLESS STEEL CONSTRUCTION**

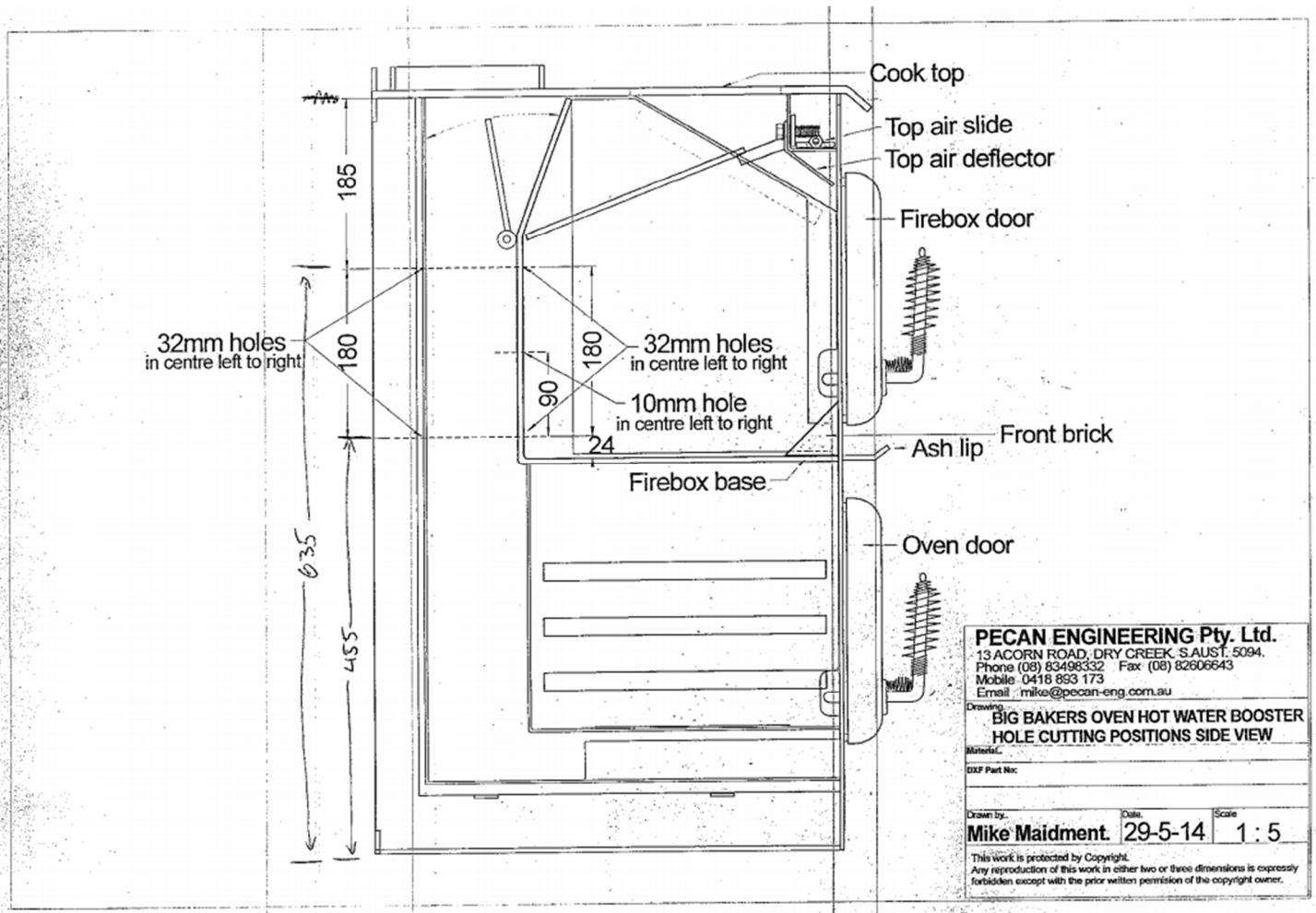
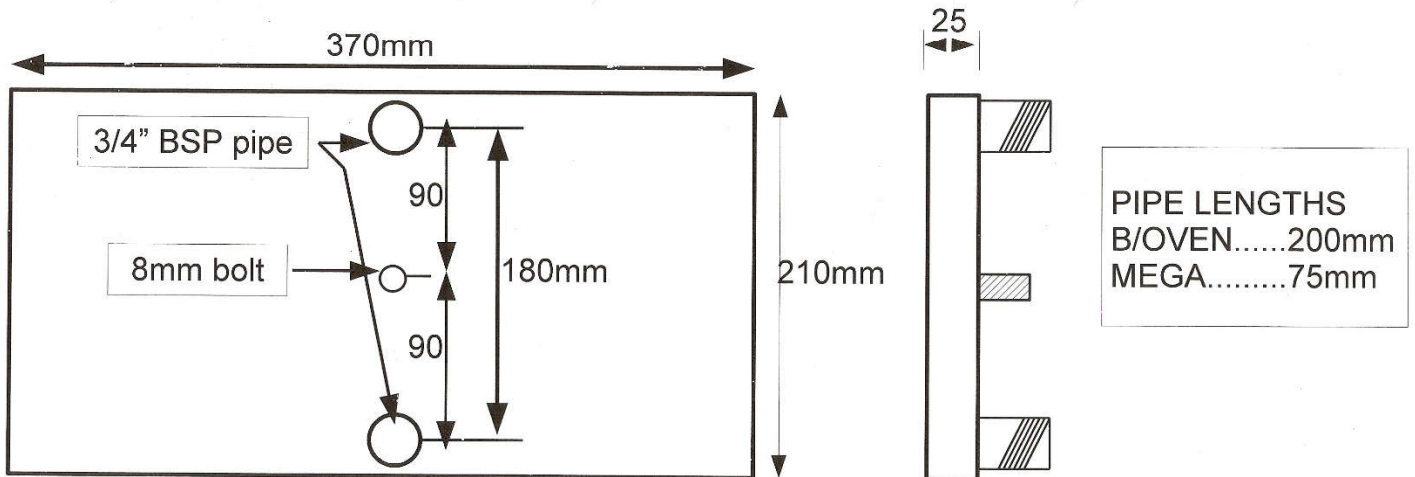

# NECTRE BAKERS OVEN.

## Hot Water Booster Position.

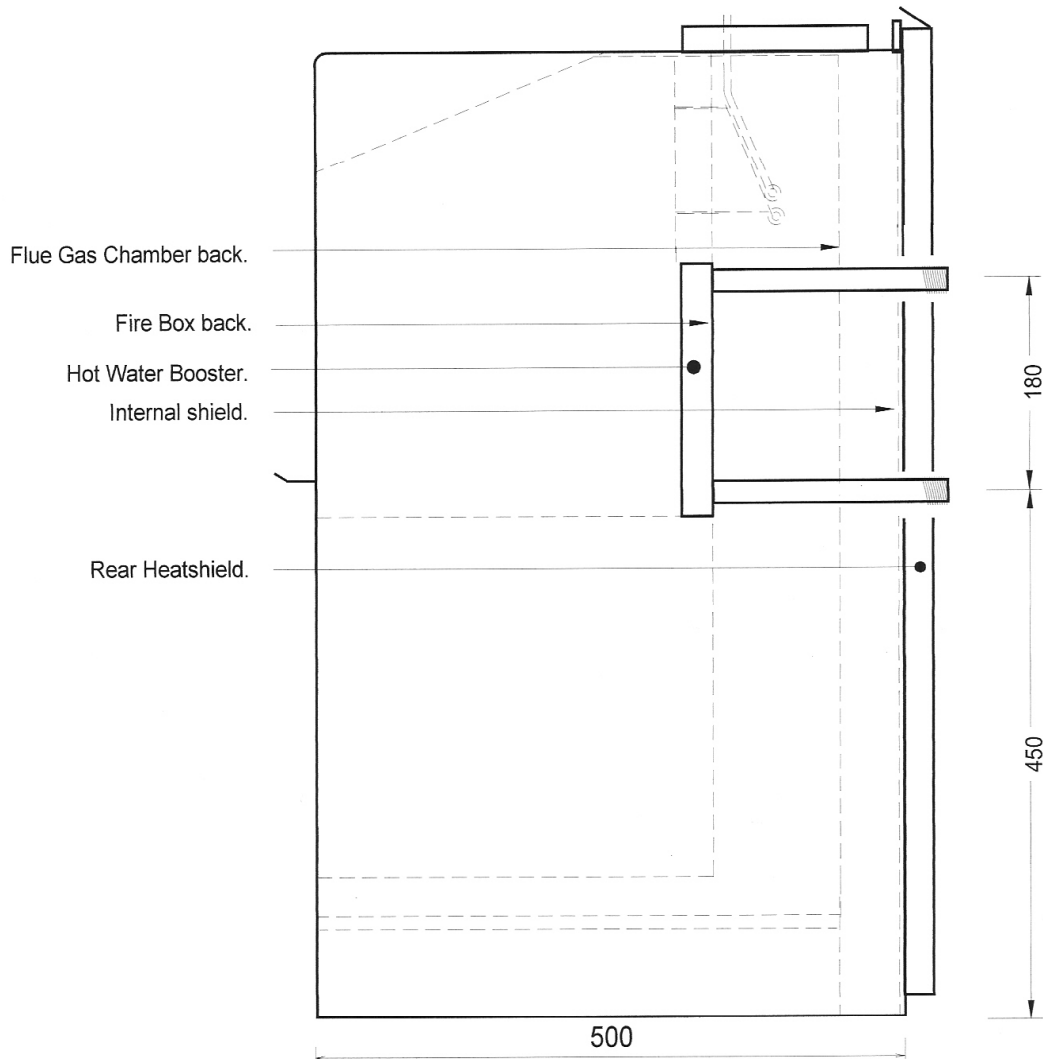

### SIDE VIEW.

**The NECTRE hot water booster is made using a certified boiler grade stainless steel and has 3/4" stainless steel inlet and outlet pipes.**



# NECTRE WATER HEATER GUIDELINES FOR LOW PRESSURE HOT WATER SYSTEMS HEADER TANK (OPEN VENTED)

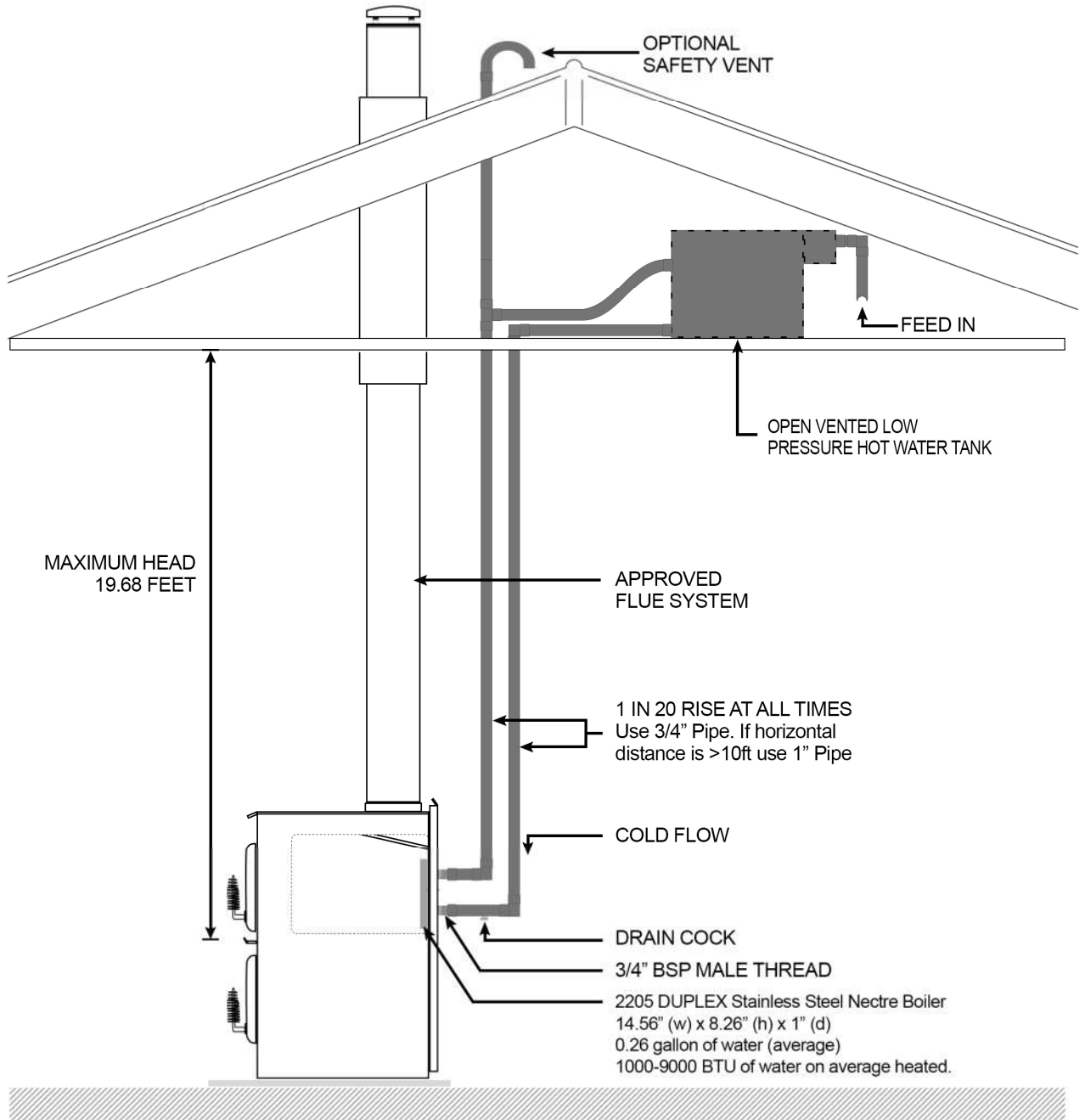

### INSTALLATION INFORMATION

Solid fuel water heater must only be fitted to open vented hot water systems. Please note that fitting to a mains pressure system is extremely dangerous and could lead to an explosion. Installation of water booster pipe work must only be carried out by a registered plumber and the appropriate requirements of all relevant building codes and best practices. Please check with your local building authority before installing this water booster.



# NECTRE WATER HEATER GUIDELINES FOR LOW PRESSURE HOT WATER SYSTEMS LOW LEVEL (OPEN VENTED)

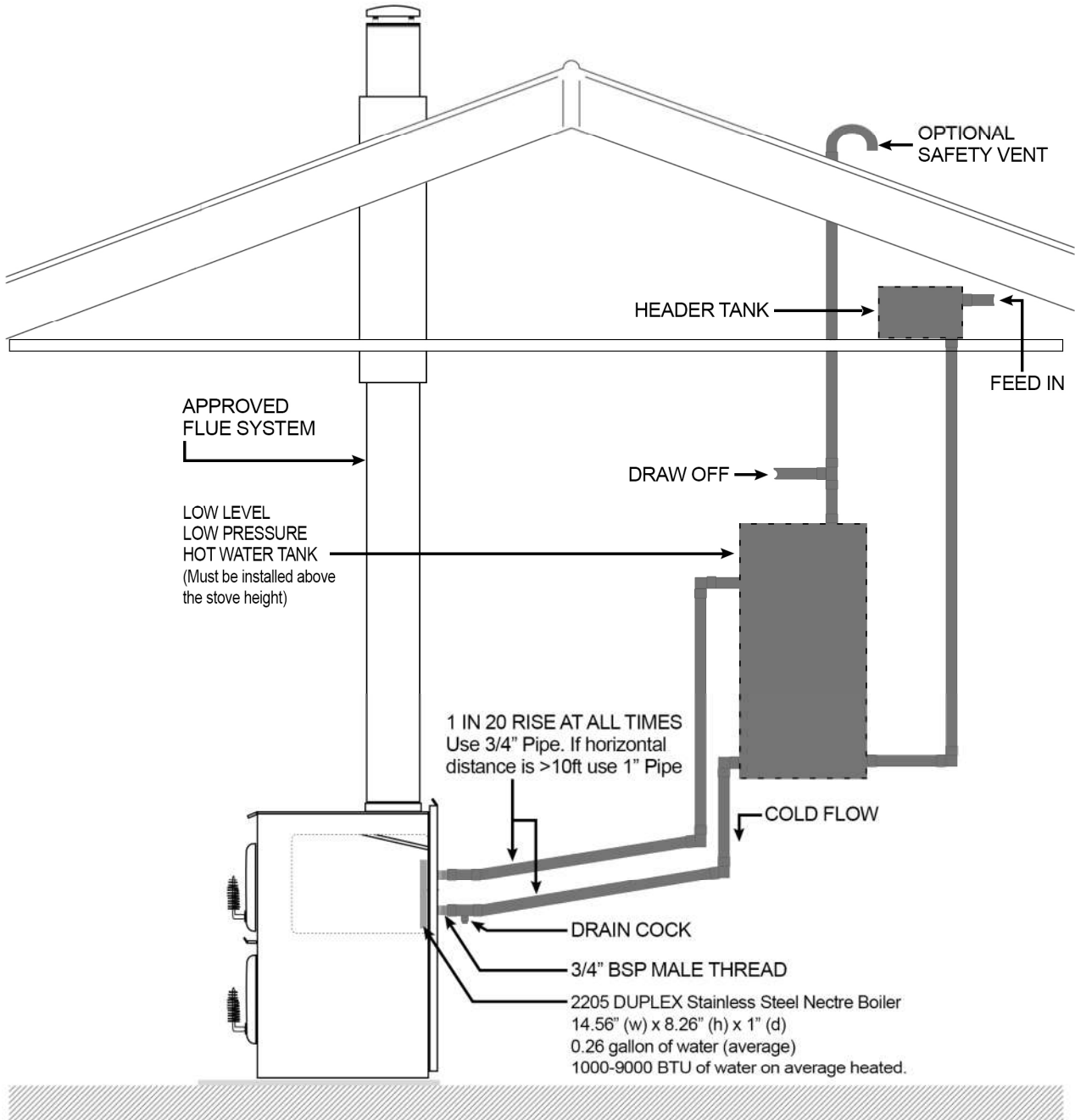

## INSTALLATION INFORMATION

Solid fuel water heater must only be fitted to open vented hot water systems. Please note that fitting to a mains pressure system is extremely dangerous and could lead to an explosion. Installation of water booster pipe work must only be carried out by a registered plumber and the appropriate requirements of all relevant building codes and best practices. Please check with your local building authority before installing this water booster.