



The logo for nectre, featuring a stylized orange flame icon above the word "nectre" in a lowercase, orange, sans-serif font.

N900

INSTALLATION INSTRUCTIONS

EFFICIENT • WARM • FRIENDLY



NECTRE N900 FREESTANDING



NECTRE N900 INBUILT



**Australian
Home Heating**
Association Inc.



**Landcare
Australia**

Glen Dimplex Australia proudly supports the activities of Landcare Australia through its membership of the AHHA.

VERSION 1.0

TABLE OF CONTENTS

1. Important Information.....	2	MASONRY INSTALLATION	
2. Assembling the Heater	2	16. Clearances to Combustible Materials	14
3. Installing the Firebox Internals	3	17. Floor Protector (Hearth).....	15
FREESTANDING INSTALLATION		18. Installing the Flue	15
4. Positioning the Open Fireplace	4	TECHNICAL DRAWINGS	
4.1. Standard Installation	4	19. N900 Freestanding.....	16
4.2. Corner Installation.....	4	20. N900 Inbuilt	17
5. Floor Protector (Hearth)	5		
5.1. 450mm or Greater above the Floor	5		
5.2. Less than 450mm above the Floor	5		
6. Reducing Clearances to Combustibles.....	6		
7. Installing the Flue	6		
8. Installing the Flue (Continued)	7		
BUILT-IN INSTALLATION			
9. Clearances to Combustible Materials	8		
10. Enclosure Construction	8		
11. Enclosure Ventilation	10		
12. Floor Protector (Hearth).....	11		
12.1. 450mm or Greater above the Floor.....	11		
12.2. Less than 450mm above the Floor	11		
13. Installing the Flue	12		
14. Fitting Receiver	12		
15. Power Supply for Fan	13		

THE INSTALLATION INSTRUCTIONS IN THIS MANUAL APPLY TO THE NECTRE N900 OPEN FIREPLACE MODELS.

THEY HAVE BEEN TESTED FOR SAFETY INSTALLATION CLEARANCES IN ACCORDANCE WITH AS/NZS 2918:2018

1. IMPORTANT INFORMATION

The unit must be installed according to all manufacturers' instructions included in this manual. The manufacturer is not liable for installations that do not meet the requirements outlined in this manual.

Most building regulatory Authorities in Australia require any wood heater installation to comply with Installation Standard AS/NZS 2918:2018. Different states and councils may have varying regulations. Check local building regulations before installing the appliance.

All Nectre wood heaters have been tested to ensure that they will meet the appropriate safety Standard requirements if the instructions in this manual are followed. As the safety and emissions performance can be affected by altering the appliance, no modifications are allowed without written permission from the manufacturer.

WE RECOMMEND THAT THE INSTALLATION OF YOUR NECTRE WOOD HEATER BE CARRIED OUT BY A QUALIFIED INSTALLER.

WARNING: THE APPLIANCE AND FLUE SYSTEM SHALL BE INSTALLED IN ACCORDANCE WITH AS/NZS 2918:2018 AND THE APPROPRIATE REQUIREMENTS OF THE RELEVANT BUILDING CODE OR CODES.

WARNING: APPLIANCES INSTALLED IN ACCORDANCE WITH THIS STANDARD SHALL COMPLY WITH THE REQUIREMENTS OF AS/NZS 4012 & AS/NZS 4013 WHERE REQUIRED BY THE REGULATORY AUTHORITY, I.E. THE APPLIANCE SHALL BE IDENTIFIABLE BY A COMPLIANCE PLATE WITH THE MARKING 'TESTED TO AS/NZS 4012 & AS/NZS 4013'.

ANY MODIFICATION OF THE APPLIANCE THAT HAS NOT BEEN APPROVED IN WRITING BY THE TESTING AUTHORITY IS CONSIDERED TO BE IN BREACH OF THE APPROVAL GRANTED FOR COMPLIANCE WITH AS/NZS 4012 & AS/NZS 4013.

CAUTION: MIXING OF APPLIANCE OR FLUE-SYSTEM COMPONENTS FROM DIFFERENT SOURCES OR MODIFYING THE DIMENSIONAL SPECIFICATION OF COMPONENTS MAY RESULT IN HAZARDOUS CONDITIONS. WHERE SUCH ACTION IS CONSIDERED, THE MANUFACTURER SHOULD BE CONSULTED IN THE FIRST INSTANCE.

CAUTION: CRACKED AND BROKEN COMPONENTS, EG. GLASS PANELS OR CERAMIC TILES, MAY RENDER THE INSTALLATION UNSAFE.

WARNING: KEEP BATTERIES OUT OF REACH OF CHILDREN

Swallowing may lead to serious injury in as little as 2 hours or death, due to chemical burns and potential perforation of the oesophagus.

If you suspect your child has swallowed or inserted a button battery immediately call the 24-hour Poisons Information Centre on 13 11 26 (in Australia) or 0800 764 766 (in New Zealand) for fast, expert advice.

Examine devices and make sure the battery compartment is correctly secured, e.g. that the screw or other mechanical fastener is tightened. Do not use if the compartment is not secure.

Dispose of used button batteries immediately and safely. Flat batteries can still be dangerous.



2. ASSEMBLING THE HEATER

The N900 Freestanding model comes in two parts - the firebox body and the wood storage base unit. To fit firebox body to base, use lifting straps to position heater on top of base and align exterior of heater with base.

Use of the included wood storage base unit is not mandatory - the firebox can be installed at floor level if desired. Floor protector requirements for this configuration are different and must be followed as per specification - see "5. Floor Protector (Hearth)".

3. INSTALLING THE FIREBOX INTERNALS

The bricks and grate will come packaged up inside the heater. Follow these steps to correctly install these components. These steps are the same no matter what install procedure is carried out.

Follow these steps after the open fireplace is installed.

1. Open spark arrestor and remove the box of bricks, grate and damper handle from inside the fireplace.
2. Bricks are placed in the retainer in a vertical orientation. Angle top edge of the brick towards the back of the firebox and slot under the retainer, allowing the bottom of the brick to sit on the horizontal lower shelf.

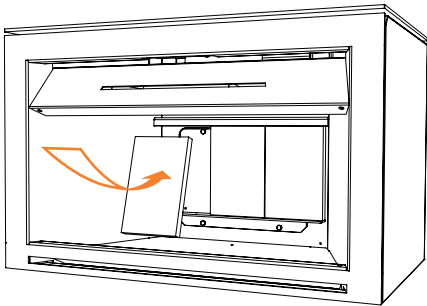

3. With the bricks installed, place the toothed grate lip in the front of the firebox with the Nectre logo on the left side facing out.

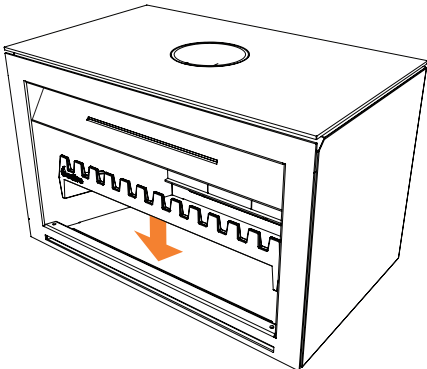

4. Place the left and right halves of the grate into the fireplace with the front and rear edges resting on the grate lip and rear shelf respectively.

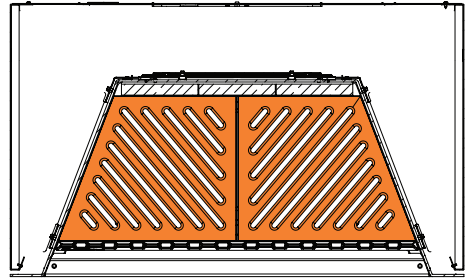

TOP VIEW

5. Slide the ash tray in underneath the grate lip, pushed back as far as it will go, close the spark arrestor.

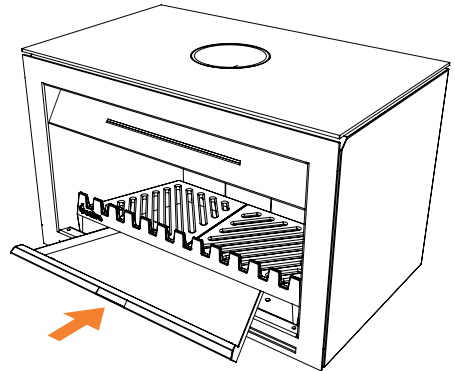

FREESTANDING INSTALLATION

4. POSITIONING THE OPEN FIREPLACE

First review the necessary clearances specified below before considering where to position the open fireplace. Also check the practicability of installing the flue system in relation to any obstructing roof beams before positioning the fireplace.

These clearance distances can only be reduced if the surrounding walls are made of non-combustible material, eg. Stone, brick, or concrete. If non-combustible material, distance can be reduced to 100 mm. Alternatively, shielding of the wall(s) can reduce clearances (refer to next section for more detail).

The height of the open fireplace firebox above the floor can affect the minimum distance the floor protector must extend out in front as well as the materials it is constructed from.

4.1. STANDARD INSTALLATION

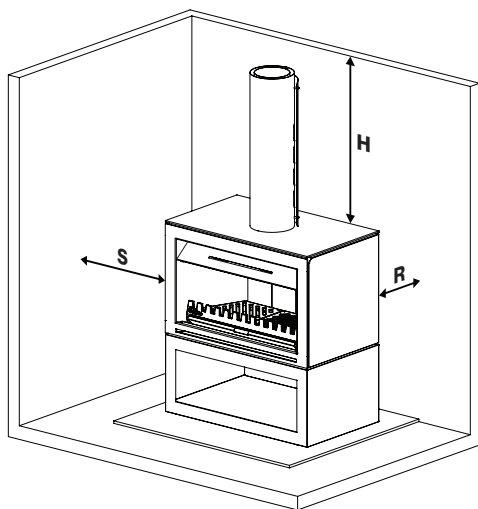

4.2. CORNER INSTALLATION

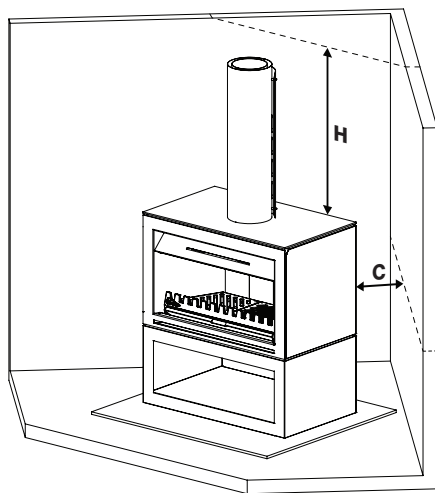

CLEARANCES STANDARD INSTALLATION

S (Side) 500mm

R (Rear) 100mm

H (Clearance to ceiling) 1300mm

CLEARANCES CORNER INSTALLATION

C (Corner) 25mm

H (Clearance to ceiling) 1300mm

5. FLOOR PROTECTOR (HEARTH)

Unless the open fireplace will be standing on a heat resistant floor such as concrete slab with slate or tiles, it will be necessary to provide a floor protector.

The construction and dimensions of the floor protector depends on the height of the open fireplace firebox above the floor - see below for detail on minimum requirements for this. It may be desirable, e.g. for aesthetic reasons, for the floor protector to be larger than these minimum dimensions. Non-combustible tiles may be laid over the top of either floor protector.

For more details and variations on floor protectors refer to AS/NZS 2918 Clause 2.2, 3.3.1, & 3.3.2.

5.1. 450MM OR GREATER ABOVE THE FLOOR

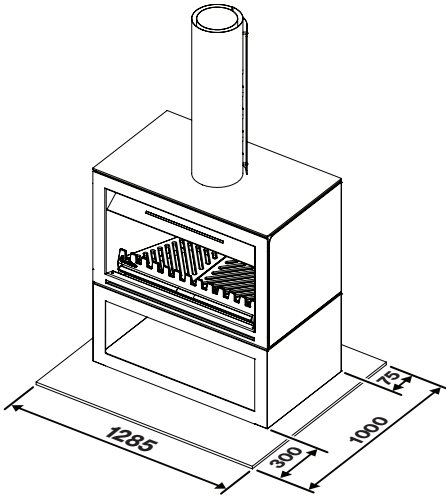

Note: including being installed on provided wood storage base

Floor protector must extend a minimum of 300mm in front of the firebox opening, extending beneath the appliance, and not less than 75mm behind (1000mm min. overall depth), and at least 200mm either side of the opening (1285mm minimum overall width).

It must be constructed from a minimum 5mm thick non-combustible material with a thermal conductivity not greater than 0.33W/m °K, equivalent to compressed fibre cement sheet.

5.2. LESS THAN 450MM ABOVE THE FLOOR

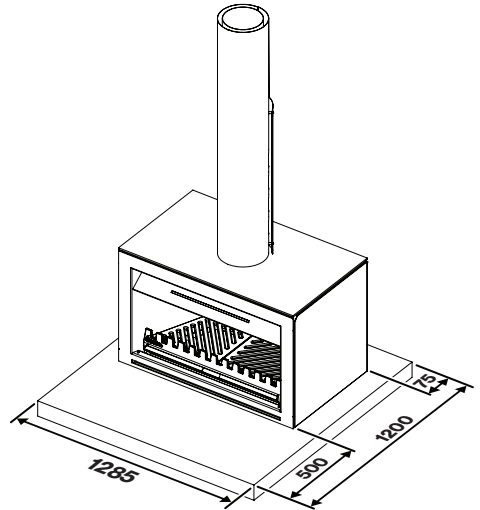

Floor protector must extend a minimum 500mm in front of the firebox opening, extending beneath the appliance, and not less than 75mm behind (1200mm min. total depth), and at least 200mm either side of the opening (1285mm minimum overall width).

It must be constructed from one of two options:

1. Skamotec 225 board – 50mm thick
2. Ventilated floor protector – two sheets of 15mm thick compressed fibre-cement sheet with a 1mm thick sheet of steel between them, spaced off the floor with 25mm high non-combustible spacers such as RHS square tubing, or equivalent, with a minimum ventilation of 2500mm² at each end between the spacers

6. REDUCING CLEARANCES TO COMBUSTIBLES

If it is necessary to install a heater closer to a combustible surface than the stated requirements in Section 2 of this Installation Guide, it must be done in accordance with Australian Standard AS/NZS 2918 Section 3, Tables 3.1 & 3.2.

Shield Construction: The shield shall be constructed from a heat resistant material. The shield must be fixed to the surface that requires protection and NOT the heater.

The Standard allows three options to reduce stated clearances.

Single layer of continuous material with Minimum Air Gap of 12mm—Clearance Factor = 0.40

Single layer of continuous material with Minimum Air Gap of 25mm—Clearance Factor = 0.30

Two spaced layers of continuous material with Minimum Air Gaps of 12mm + 12mm—Clearance Factor = 0.20

The shielding must be open at the top and bottom (vented) to allow a continuous air flow. It is this air flow that keeps the surface requiring protection cool. Fixings should not impede this air flow.

The shielding needs to go far enough along and up the wall so that the original side and rear required clearances are not compromised. As the flue is now closer to the wall the shielding should also protect the wall from the flue pipe.

For example:

Side wall clearance for the N900 is 500mm.

A 12mm gapped shield on the wall with a factor of 0.40.

Calculate: $500\text{mm} \times 0.40 = 200\text{mm}$. This is the new side wall minimum clearance.

The shielding needs to be large enough so that none of the original clearances of 500mm are compromised.

7. INSTALLING THE FLUE

The flue system used when installing the open fireplace **MUST** comply with the current installation standard AS/NZS 2918.

Full instructions on the installation of the flue will be supplied with the flue kit. These **MUST** be adhered to, including the minimum exit height from the top of the floor protector being not less than 4.6m, and the minimum exit height above the roof line of roof ridge as detailed in the AS/NZS 2918.

The flue kit is supplied with the freestanding open fireplace. Note that this flue kit is different to the one supplied with the Built-in model of N900. They are not interchangeable.

The freestanding flue kit consists of:

- 4 x 900mm lengths of 8 inch stainless steel active flue
- 1 x 900mm length of 10 inch, slotted stainless steel outer casing with an external rear heat shield fitted, painted black
- 1 x 900mm length of 10 inch stainless steel outer casing with an internal rear heat shield painted black
- 2 x 900mm lengths of 10 inch stainless steel outer casing
- 2 x 900mm lengths of 12 inch galvanised steel outer casing
- 1 x 12 inch ceiling drop box with 5000mm² ventilation
- 1 x ceiling flange
- 1 x stainless steel flue cowl for 8 inch flue
- 1 x angle support brackets

8. INSTALLING THE FLUE (CONTINUED)

Procedure:

1. Installing 8 inch active flue – the first length of 8 inch stainless steel flue inserted into the spigot of the appliance can be differentiated by the other three lengths by a larger crimp and swage at one end. Install the remaining three lengths of 8 inch flue as normal.
2. 10 inch outer casing with external shield – the first length of outer casing, resting on top of the appliance, is the slotted length with the external heat shield. Orientate the outer casing so that the external shield is closest to the rear wall.
3. 10 inch outer casing with internal shield – the second length of outer casing, inserted into the first length, is the one with the internal heat shield. Orientate the second length of outer casing so that the internal shield is closest to the rear wall.
4. Additional black-painted 10 inch outer casing – depending on the height of the ceiling above the appliance, it may be necessary to order an additional length of 10 inch stainless steel outer casing painted black so that it may extend into the ceiling drop box.

All other aspects of the flue kit must be installed in accordance with AS/NZS 2918.

BUILT-IN INSTALLATION

Refer to this section for clearance requirements and instructions if the heater is to be in a built-in installation.

NOTE: Receiver for fan remote control must be fitted before installing the appliance. Refer to “14. Fitting Receiver” for more detail.

A licensed accredited installer should install all wood heaters. Please ask your retailer to locate an installer.

9. CLEARANCES TO COMBUSTIBLE MATERIALS

The table below gives minimum clearances from the appliance to combustible materials. All dimensions are from the surfaces on the outer box of the appliance (see diagram in in following section “10. Enclosure Construction”). Internal clearances are within the enclosure, and external clearances are outside the enclosure (inside the area to be heated).

CLEARANCES BUILT-IN INSTALLATION

A (Rear internal)	80mm
B (Side Internal)	40mm
C (Above internal)	200mm
D (Ceiling internal)	1200mm
E (Side wall external)	550mm
F (Ceiling external)	1200mm

10. ENCLOSURE CONSTRUCTION

The following drawing shows the construction of an enclosure, with minimum clearances for the appliance to be installed (as tested in accordance with AS/NZS 2918 Appendix B).

- The frame is constructed of 90x45mm timber, displayed as dashed lines.
- The cladding on the front wall must be a non-combustible material with a minimum thickness of 10mm.
- If the cladding is greater than 10mm thick, the front edge of the outer “skin” on the appliance can be adjusted by loosening the screws and the narrow cover on top and sides can be slid back sufficient to allow for the greater thickness material to recess behind the front fascia of the appliance.
- The firebox can be installed on 50mm thick Skamotec 225 board with overall dimensions of 1000mm wide by 600mm deep.
- If installed 250mm or more above the floor, the firebox can be installed on two 15mm thick compressed fibre cement sheets with overall dimensions of 900mm wide by 480mm deep extending back from the inside face of the front of the enclosure, supported on a timber structure beneath as shown in the following diagram.
- If installed at ground level, the firebox must be installed on the same construction material as the floor protector in front of the firebox, and extend to the rear of the firebox cabinet.

Note: Additional supports should be used to support the weight of the heater and flue system. These have not been shown in the diagram.

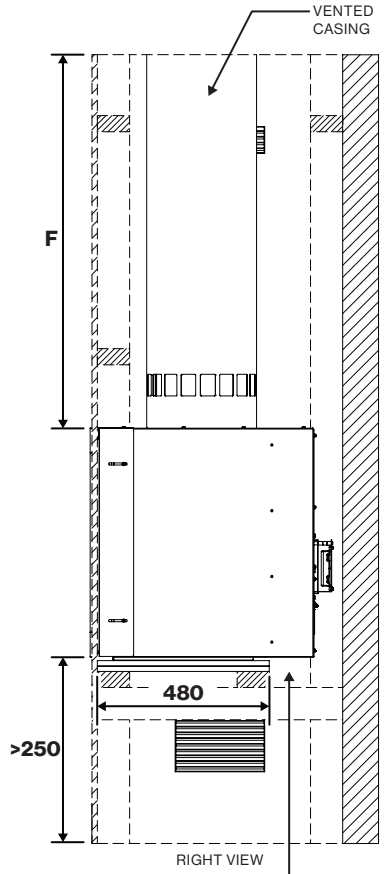
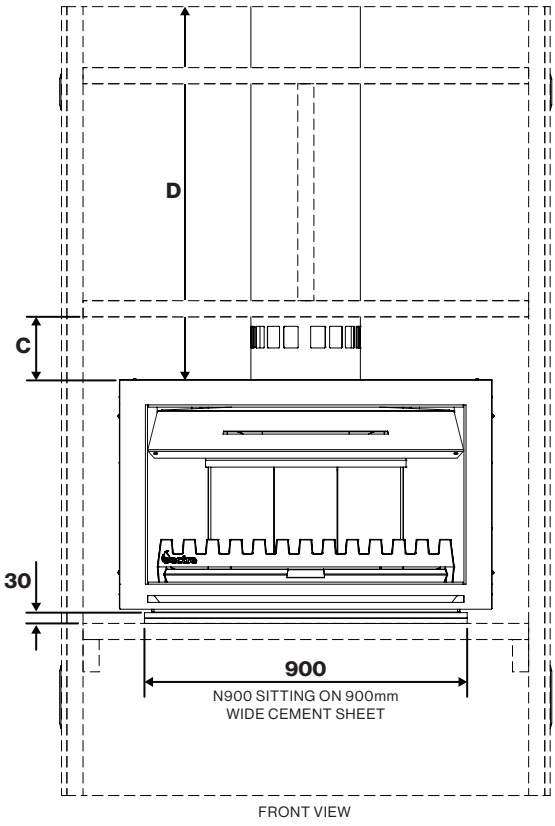
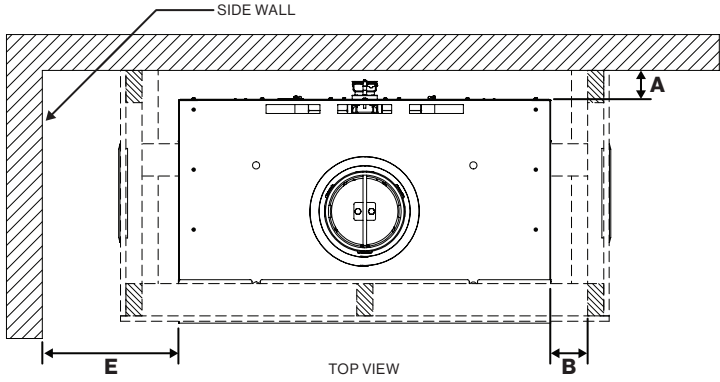

AREA BEHIND CEMENT SHEET MUST BE CLEAR OF COMBUSTIBLES FOR MIN. 250mm BELOW HEATER

11. ENCLOSURE VENTILATION

The enclosure must be ventilated. The purpose of the vents is to allow cooler air to be drawn into the enclosure through the bottom vents, and warm air out through the top vents via natural convection back into the room.

Two vents, each with a minimum free area of $14,700\text{mm}^2$, fitted on either side of the enclosure, not more than 200mm above the floor AND two additional vents, each with a minimum free area of 7350mm^2 , fitted on either side of the enclosure, not more than 200mm below the ceiling.

Ensure that adequate ventilation from the lower vents can get past the open fireplace cabinet.

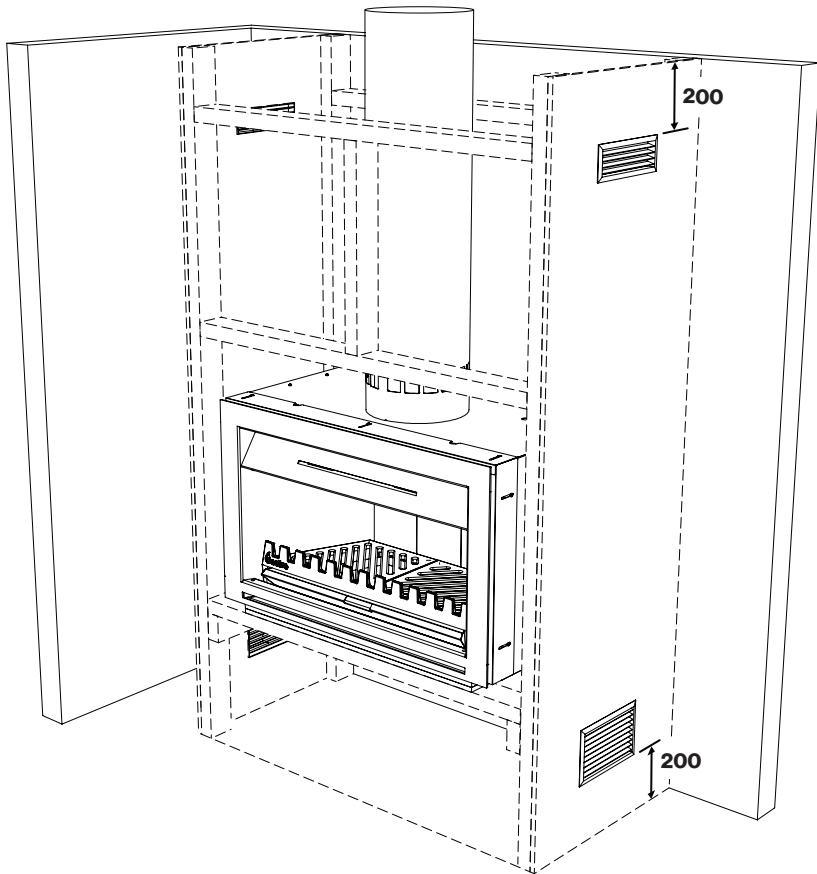

12. FLOOR PROTECTOR (HEARTH)

The construction and dimensions of the floor protector depends on the height of the base of the firebox above the floor - see below for detail on minimum requirements for this. It may be desirable, e.g. for aesthetic reasons, for the floor protector to be larger than these minimum dimensions. Non-combustible tiles may be laid over the top of either floor protector.

For more details and variations on floor protectors refer to AS/NZS 2918 Clause 2.2, 3.3.1, & 3.3.2.

12.1. 450MM OR GREATER ABOVE THE FLOOR

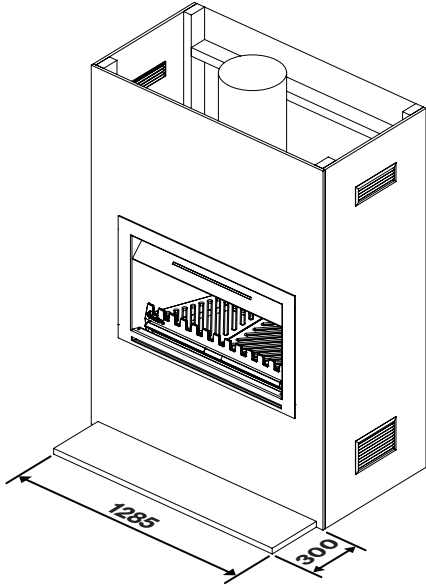

Floor protector must extend a minimum of 300mm in front of the firebox opening, and at least 200mm either side of the opening (1285mm minimum overall width).

It must be constructed from a minimum 5mm thick non-combustible material with a thermal conductivity not greater than $0.33\text{W/m}^{\circ}\text{K}$, equivalent to compressed fibre cement sheet.

12.2. LESS THAN 450MM ABOVE THE FLOOR

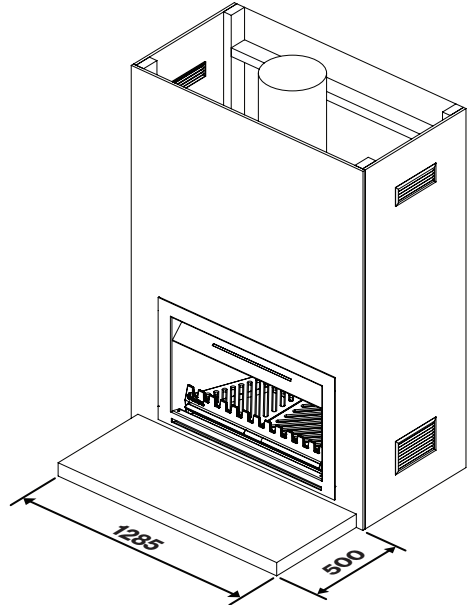

Floor protector must extend a minimum of 500mm in front of the firebox opening, and at least 200mm either side of the opening (1285mm minimum overall width). It must be constructed from one of two options:

1. Skamotec 225 board – 50mm thick
2. Ventilated floor protector – two sheets of 15mm thick compressed fibre-cement sheet with a 1mm thick sheet of steel between them, spaced off the floor with 25mm high non-combustible spacers such as RHS square tubing, or equivalent, with a minimum ventilation of 2500mm^2 at each end between the spacers

Note that if the firebox is less than 250mm above the floor, the floor beneath the firebox within the enclosure must be protected with the same material construction as the floor protector in front of the enclosure.

13. INSTALLING THE FLUE

The flue system used when installing the open fireplace MUST comply with the current installation standard AS/NZS 2918.

Full instructions on the installation of the flue will be supplied with the flue kit. These MUST be adhered to, including the minimum exit height from the top of the floor protector being not less than 4.6m, and the minimum exit height above the roof line of roof ridge as detailed in the AS/NZS 2918.

The flue kit is supplied with the built-in open fireplace. Note that this flue kit is different to the one supplied with the freestanding model of N900. They are not interchangeable.

The Built-in flue kit consists of:

- 5 x 900mm lengths of 8 inch stainless steel active flue
- 1 x 900mm length of 10 inch, slotted stainless steel inner casing
- 4 x 900mm lengths of 10 inch stainless steel inner casing
- 1 x 900mm length of 12 inch, slotted galvanised steel outer casing
- 4 x 900mm lengths of 12 inch galvanised steel outer casing
- 1 x stainless steel flue cowl for 8 inch flue
- 1 x angle support brackets

Procedure:

1. Installing 8 inch active flue – the first length of 8 inch stainless steel flue inserted into the spigot of the appliance can be differentiated by the other lengths by a larger crimp and swage at one end. Install the remaining lengths of 8 inch flue as normal.
2. 10 inch slotted inner casing – the first length of inner casing, resting on top of the appliance, is the slotted length, installed with the ventilation slots at the bottom. Install the remaining inner casing as normal.
3. 12 inch slotted outer casing – the first length of outer casing, resting on top of the appliance, is the slotted length, installed with the ventilation slots at the bottom. Install the remaining outer casing as normal.

All other aspects of the flue kit must be installed in accordance with AS/NZS 2918.

14. FITTING RECEIVER

NOTE: Receiver for fan remote control must be fitted before installing the appliance. The receiver unit control will be supplied packaged inside the firebox.

- On the rear of the appliance is a bracket protruding from the centre of the rear surface.
- Connect the two plugs from the rear of the appliance to the receiver unit.
- Locate and insert the tab on the fan receiver assembly in the slot at the bottom of the bracket.
- Insert the supplied M6 screw through the hole in the top of the receiver assembly, thread the spacers over the screw, and then fasten the screw to the nutsert at the top of the bracket. Tighten until firm.

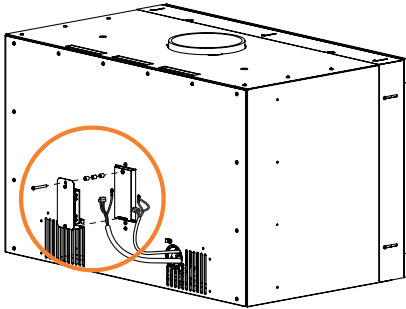

15. POWER SUPPLY FOR FAN

It may be desirable to provide a power point in the cavity under the heater for connecting the fan in the heater. If the cavity under the heater will not be accessible once the heater is installed (such as through a removable vent) then ensure an extension cord long enough to reach out of the front of the opening is lying in the base of the cavity.

When connecting the lead from the fan to the extension cord, it is suggested to tape the connection together. This is to prevent separation if the remote receiver or fan requires removal and the lead needs to be pulled through.

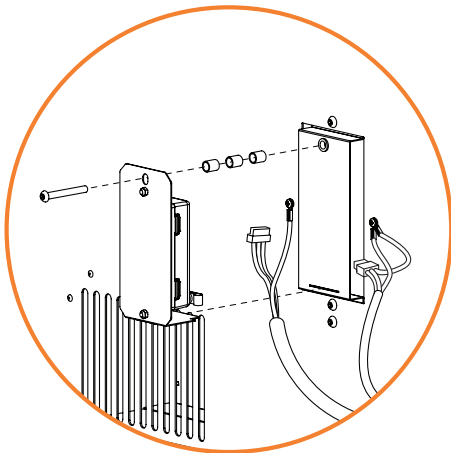

MASONRY INSTALLATION

Refer to this section for clearance requirements and instructions if the heater is to be in a masonry installation.

NOTE: Receiver for fan remote control must be fitted before installing the appliance. Refer to “14. Fitting Receiver” for more detail.

A licensed accredited installer should install all wood heaters. Please ask your retailer to locate an installer.

16. CLEARANCES TO COMBUSTIBLE MATERIALS

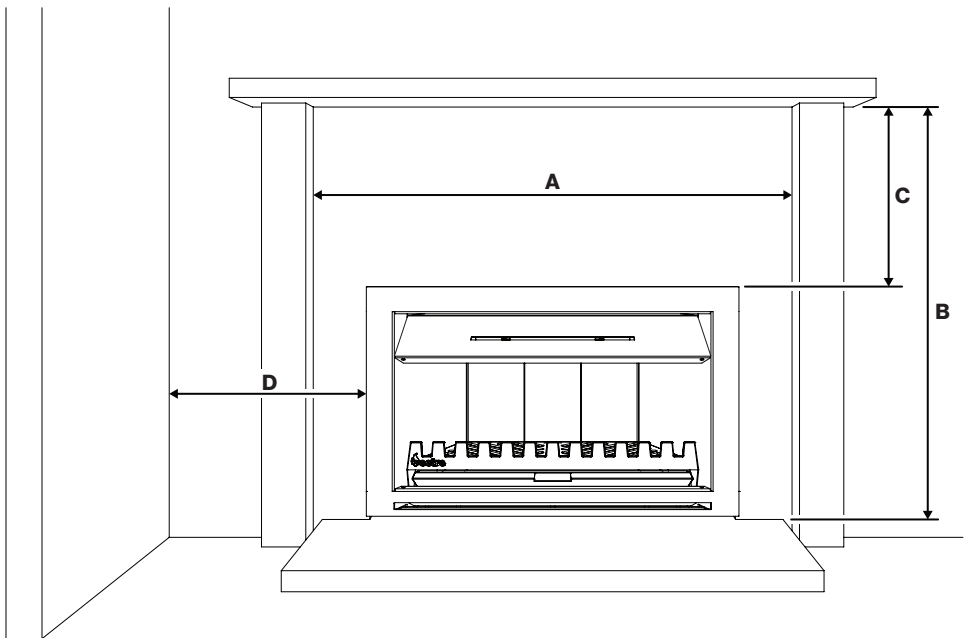

The dimensions given in the table to the right and the diagram above represent the minimum clearance (in millimetres) to combustible materials, such as a mantelpiece with columns, when installed in a non-combustible fireplace.

Note – mantelpiece clearance can be reduced by installing a heat shield beneath it in accordance with AS/NZS 2918.

CLEARANCES MASONRY INSTALLATION

A (Width between mantelpiece columns)	1335mm
B (Height from mantelpiece from hearth)	1400mm
C (Height to mantelpiece from appliance)	750mm
D (Distance to side wall)	550mm

17. FLOOR PROTECTOR (HEARTH)

The minimum dimensions and construction materials for the floor protector when installed in a masonry fireplace are the same as for a Built-In installation.

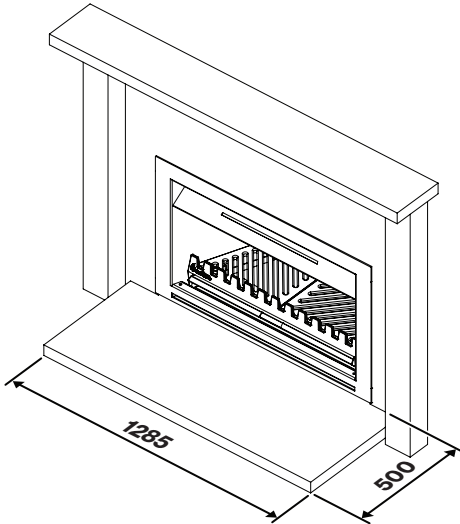

Floor protector must extend a minimum of 500mm in front of the firebox opening, and at least 200mm either side of the opening (1285mm minimum overall width). It must be constructed from one of two options:

1. Skamotec 225 board – 50mm thick
2. Ventilated floor protector – two sheets of 15mm thick compressed fibre-cement sheet with a 1mm thick sheet of steel between them, spaced off the floor with 25mm high non-combustible spacers such as RHS square tubing, or equivalent, with a minimum ventilation of 2500mm² at each end between the spacers

18. INSTALLING THE FLUE

If the appliance is installed in a masonry fireplace with masonry chimney, the flue must be installed in accordance with AS/NZS 2918.

If the chimney is not masonry and is constructed wholly or partly from combustible material, it must be installed with the manufacturer-supplied Built-In flue kit.

Any gaps between the 8 inch active flue and the flue spigot on the appliance should be filled with either stove cement designed for this purpose or high temperature cloth tape.

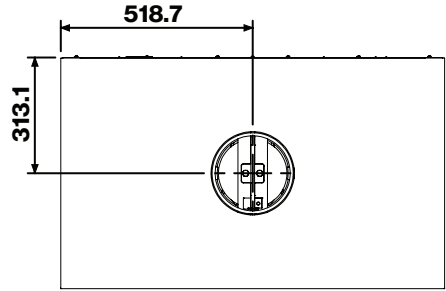
TECHNICAL DRAWINGS**19. N900 FREESTANDING**

TOP

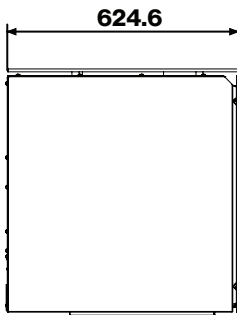

LEFT

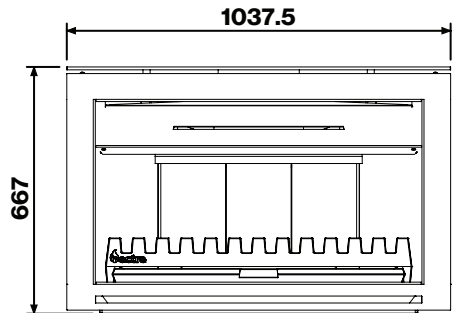

FRONT

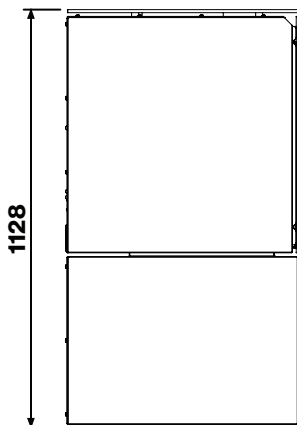

LEFT

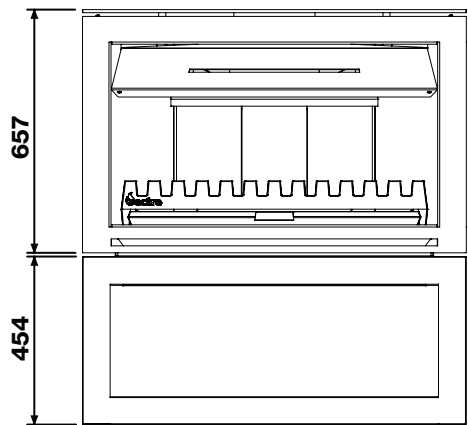

FRONT

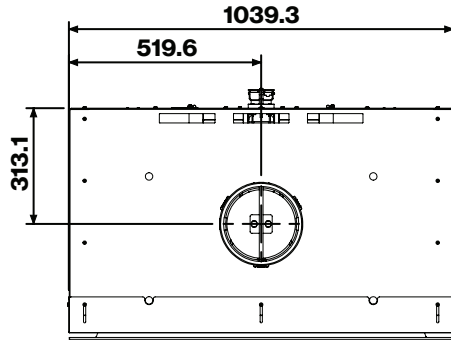
20. N900 INBUILT

TOP

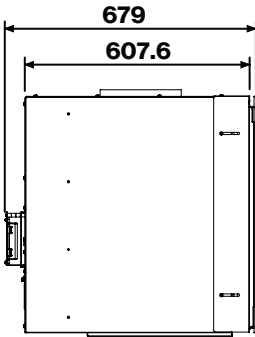

LEFT

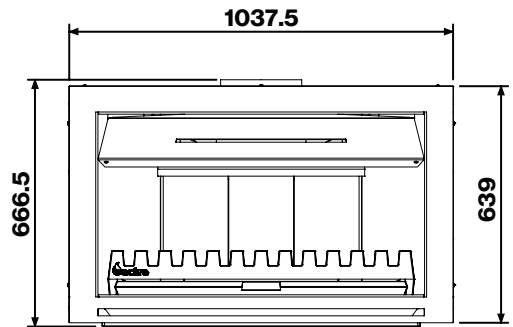

FRONT



Glen Dimplex Australia Pty Ltd

8 Lakeview Drive,
Scoresby Victoria 3179
Australia

T: 1300 554 155

General and Sales Enquiries: flame.care@glendimplex.com.au

Technical Service: flame.support@glendimplex.com.au

www.glendimplex.com.au