



nectre.

MK1

INSTALLATION INSTRUCTIONS

EFFICIENT • WARM • FRIENDLY



NECTRE MK1 (LE) LEGS



NECTRE MK1 (LE) PEDESTAL



Glen Dimplex Australia proudly supports the activities of Landcare Australia through its membership of the AHHA.

TABLE OF CONTENTS

| | |
|---|---|
| 1. Important Information..... | 2 |
| 2. Installing the Heater..... | 2 |
| 2.1. Fitting Rear Heat Shield | 2 |
| 2.2. Positioning the Heater..... | 3 |
| 2.2.1. Standard Installation | 3 |
| 2.2.2. Corner Installation..... | 3 |
| 2.3. Floor Protector (Hearth) | 4 |
| 3. Reducing Clearances to Combustibles..... | 4 |
| 4. Installing the Flue | 5 |
| 5. Installing the Flue (Continued) | 6 |
| 5.1. Fitting Flue Seal..... | 6 |
| 6. Installing the Fire Bricks | 6 |
| 7. Installing the Baffle Plates | 7 |
| 8. Installing Ash Plate..... | 7 |
| 9. Technical Drawings..... | 8 |
| 9.1. MK1 Legs..... | 8 |
| 9.2. Mk1 Pedestal..... | 9 |

THE INSTALLATION INSTRUCTIONS IN THIS MANUAL APPLY TO THE NECTRE MK1 (LE).

IT HAS BEEN TESTED FOR EMISSIONS AND EFFICIENCY AND COMPLIES ACCORDING TO AS/NZS 4012:2014 & AS/NZS 4013:2014.

IT HAS ALSO BEEN TESTED FOR SAFETY INSTALLATION CLEARANCES IN ACCORDANCE WITH AS/NZS 2918:2018

1. IMPORTANT INFORMATION

Most building regulatory Authorities in Australia require any wood heater installation to comply with Installation Standard AS/NZS 2918:2018. Different states and councils may have varying regulations. Check local building regulations before installing the appliance.

All Nectre wood heaters have been tested to ensure that they will meet the appropriate safety Standard requirements if the instructions in this manual are followed. As the safety and emissions performance can be affected by altering the appliance, no modifications are allowed without written permission from the manufacturer.

WE RECOMMEND THAT THE INSTALLATION OF YOUR NECTRE WOOD HEATER BE CARRIED OUT BY A QUALIFIED INSTALLER.

WARNING: THE APPLIANCE AND FLUE SYSTEM SHALL BE INSTALLED IN ACCORDANCE WITH AS/NZS 2918:2018 AND THE APPROPRIATE REQUIREMENTS OF THE RELEVANT BUILDING CODE OR CODES.

WARNING: APPLIANCES INSTALLED IN ACCORDANCE WITH THIS STANDARD SHALL COMPLY WITH THE REQUIREMENTS OF AS/NZS 4012 & AS/NZS 4013 WHERE REQUIRED BY THE REGULATORY AUTHORITY, I.E. THE APPLIANCE SHALL BE IDENTIFIABLE BY A COMPLIANCE PLATE WITH THE MARKING 'TESTED TO AS/NZS 4012 & AS/NZS 4013'.

ANY MODIFICATION OF THE APPLIANCE THAT HAS NOT BEEN APPROVED IN WRITING BY THE TESTING AUTHORITY IS CONSIDERED TO BE IN BREACH OF THE APPROVAL GRANTED FOR COMPLIANCE WITH AS/NZS 4012 & AS/NZS 4013.

CAUTION: MIXING OF APPLIANCE OR FLUE-SYSTEM COMPONENTS FROM DIFFERENT SOURCES OR MODIFYING THE DIMENSIONAL SPECIFICATION OF COMPONENTS MAY RESULT IN HAZARDOUS CONDITIONS. WHERE SUCH ACTION IS CONSIDERED, THE MANUFACTURER SHOULD BE CONSULTED IN THE FIRST INSTANCE.

CAUTION: CRACKED AND BROKEN COMPONENTS, EG. GLASS PANELS OR CERAMIC TILES, MAY RENDER THE INSTALLATION UNSAFE.

2. INSTALLING THE HEATER

2.1. FITTING REAR HEAT SHIELD

Before working out the position of the heater and the relevant clearances to combustible surfaces, fit the rear outer heat shield with the curved end at the top and spacers between the inner heat shield:

1. On the rear of the heater, there are four 32mm long screws fixing the outer heat shield, upside-down, to the inner heat shield. Remove the screws and the outer heat shield.
2. Rotate the outer heat shield 180 degrees so that the curved end is on top and angled towards the front of the heater.
3. A plastic packet with four 20mm long cylinder spacers will be inside the heater. Relocate the four 32mm long screws through the original holes in the outer heat shield, slide a spacer over each screw, and re-fasten to the inner heat shield.

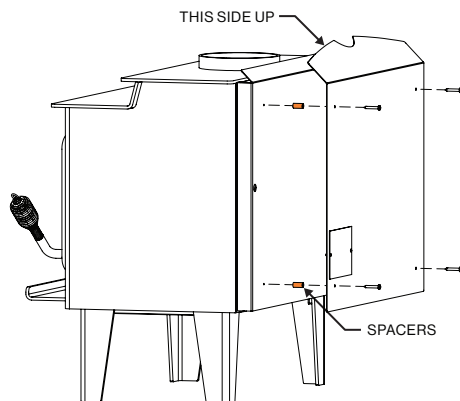

2.2. POSITIONING THE HEATER

First review the necessary clearances specified below before considering where to position the heater.

Check the practicability of installing the flue system in relation to any obstructing roof beams before positioning the heater.

Optional side shields are available for the Mk1 (sold separately) which can help to reduce side and corner clearances.

These clearance distances can only be reduced if the surrounding walls are made of non-combustible material, eg. Stone, brick, or concrete. If non-combustible material, distance can be reduced to 100 mm. Alternatively, shielding of the wall(s) can reduce clearances (refer to next section for more detail).

2.2.1. STANDARD INSTALLATION

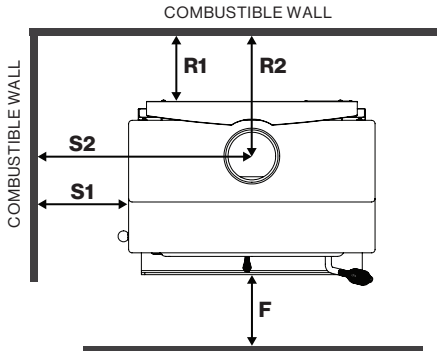

2.2.2. CORNER INSTALLATION

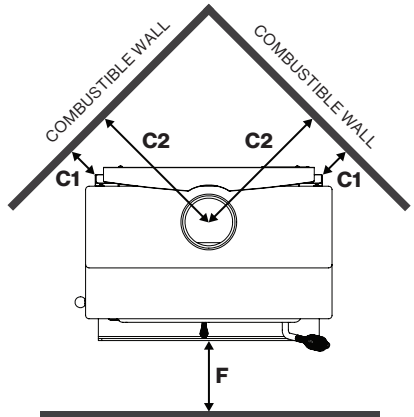

CLEARANCES STANDARD INSTALLATION

| | Without side shields | With side shields |
|-----------|----------------------|-------------------|
| Side - S1 | 650mm | 500mm |
| Side - S2 | 1013mm | 863mm |
| Rear - R1 | 140mm | 140mm |
| Rear - R2 | 301mm | 301mm |
| Floor - F | 400mm | 400mm |

CLEARANCES CORNER INSTALLATION

| | Without side shields | With side shields |
|-------------|----------------------|-------------------|
| Corner - C1 | 500mm | 300mm |
| Corner - C2 | 834mm | 634mm |
| Floor - F | 400mm | 400mm |

2.3. FLOOR PROTECTOR (HEARTH)

Unless the heater will be standing on a heat resistant floor such as concrete slab with slate or tiles, it will be necessary to provide a floor protector (hearth).

The dimensions given on the previous page ("2.2. Positioning the Heater") are the minimum required for the floor protector to extend beyond the firebox door opening. It must extend no less than 400 mm in front of the door opening, no less than 200mm both sides of the door opening, and extend under the heater.

| MEASUREMENT | WIDTH |
|-------------------------------|-------|
| Door opening width | 500mm |
| Minimum floor protector width | 900mm |

Minimum dimensions for floor protector are 900mm wide by 900mm deep.

It may be desirable, e.g. for aesthetic reasons, for the floor protector to be larger than these minimum dimensions.

The floor protector shall be constructed from non-combustible material no less than 15mm thick and with a thermal conductivity not greater than 0.33W/m °K, eg. compressed-fibre cement sheet.

The floor protector may be laid directly on the combustible floor.

For more details and variations on floor protectors refer to AS/NZS 2918 Clause 2.2, 3.3.1, & 3.3.2

3. REDUCING CLEARANCES TO COMBUSTIBLES

If it is necessary to install a heater closer to a combustible surface than the stated requirements in Section 2 of this Installation Guide, it must be done in accordance with Australian Standard AS/NZS 2918 Section 3, Tables 3.1 & 3.2.

Shield Construction: The shield shall be constructed from a heat resistant material. The shield must be fixed to the surface that requires protection and NOT the heater.

The Standard allows three options to reduce stated clearances.

Single layer of continuous material with Minimum Air Gap of 12mm—Clearance Factor = 0.40

Single layer of continuous material with Minimum Air Gap of 25mm—Clearance Factor = 0.30

Two spaced layers of continuous material with Minimum Air Gaps of 12mm + 12mm—Clearance Factor = 0.20

The shielding must be open at the top and bottom (vented) to allow a continuous air flow. It is this air flow that keeps the surface requiring protection cool. Fixings should not impede this air flow.

The shielding needs to go far enough along and up the wall so that the original side and rear required clearances are not compromised. As the flue is now closer to the wall the shielding should also protect the wall from the flue pipe.

For example:
Side wall clearance for the Mk1 is 650mm.

A 12mm gapped shield on the wall with a factor of 0.40.

Calculate: 650mm x 0.40 = 260mm. This is the new side wall minimum clearance.

The shielding needs to be large enough so that none of the original clearances of 650mm are compromised.

4. INSTALLING THE FLUE

The flue system used when installing the heater MUST comply with the current installation standard AS/NZS 2918.

Full instructions on the installation of the flue will be supplied with the flue kit. These MUST be adhered to, including the minimum exit height from the top of the floor protector being not less than 4.6m, and the minimum exit height above the roof line of roof ridge as detailed in the instructions.

The MK1 uses a 6"/150mm active flue and must be fitted with one of the following:

1. Rear Flue Shield:

- a. 900 mm long, minimum 160° arc, stainless steel unpainted rear flue shield with 25mm gap between it and the active flue.

2. Decromesh / Solid Flue Shield:

Note - must be installed with with an internal **heat shield/ reflector** AND ventilated locating ring at base of flue shielding.

- a. A full length, half radius perforated decromesh flue shield extending from the heater through into the drop box penetrating the ceiling with the perforated surface facing the front, OR equivalent in solid outer flue shield casing (7.75" diameter)
- b. The first length of casing must have an inner shield extending the full length and positioned so that the inner shield is between the active flue and the rear wall.
- c. The manufacturer's 'locating ring' must be used to support the flue shielding up off the heater top. It is important that air can be drawn into the base and rear of the flue shielding.

- d. Place the locating ring around the flue spigot (resting on the heater top) and then place the first length of active flue into the spigot. Slide the shielding over the active flue. Locate the bottom of the decromesh or solid outer shield inside the locating ring.

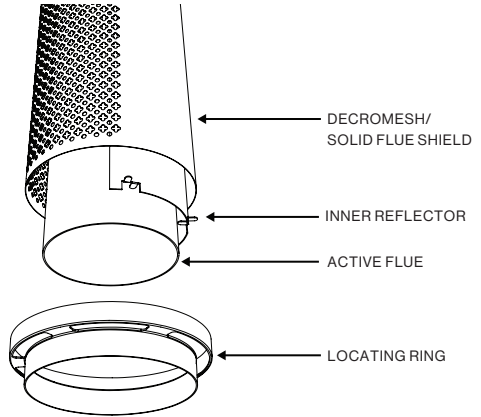

- e. Depending on the supplier, the flue shielding can be one of three sizes – 200 mm, 7¾ inch, or 8 inch diameter. The locating ring will fit the two smaller diameters but not the 8 inch. In this scenario, snip through the outer ring with tin-snips as shown in the drawing below. Bend the two "arms" in a little so they ends don't project out when fitted to the decromesh. Ensure that the snipped section is at the rear of the flue, out of sight.

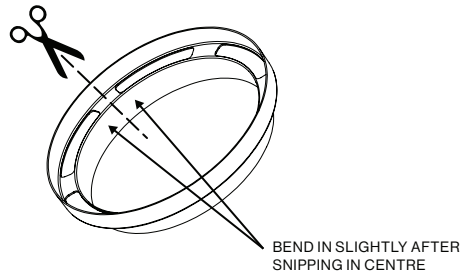

5. INSTALLING THE FLUE (CONTINUED)

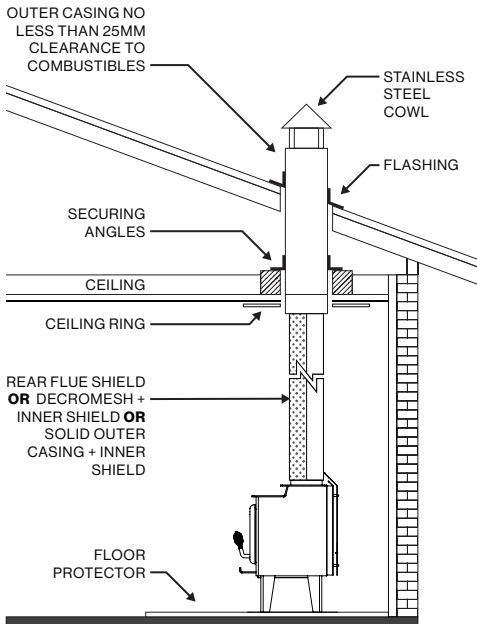

If the draft is insufficient or periodic down drafting occurs and the heater smokes or only burns slowly, extending the flue or fitting a specialised cowl will usually resolve the issue.

5.1. FITTING FLUE SEAL

Any gaps between the inside of the flue spigot and the active flue should be sealed. This can be done by wrapping the bottom of the flue with a length of fibreglass tape. Alternatively, high temperature stove cement can also be used.

6. INSTALLING THE FIRE BRICKS

The Nectre Mk1 comes with 9 full size bricks (230(h) x 115(w) x 38(d)mm) and 2 half size bricks (230(h) x 55(w) x 38(d)mm).

Raise the brick retainer (supplied inside the firebox) and start standing the bricks up against the rear and sides of the firebox as shown in the diagram below.

Once bricks are in, fit the retainer over the top to hold them in place.

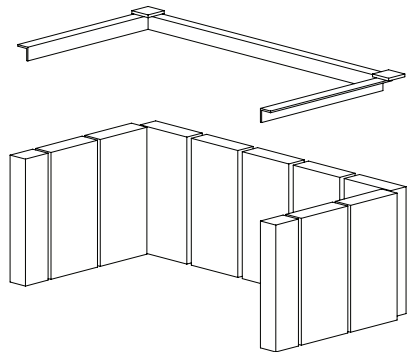

7. INSTALLING THE BAFFLE PLATES

The Nectre Mk1 is supplied with two baffle plates:

Upper baffle plate – 400(w) x 160(d) x 5(h) mm.

1. Fit the upper baffle plate first.
2. With the plate in a horizontal position, slide it up and over the shorter of the two sets of support hooks welded to the top of the firebox.
3. Slide the plate back so that it rests on the upper support rod on rear wall of the firebox.
4. The upper baffle plate should be in a horizontal orientation.

Lower baffle plate – 495(w) x 250(d) x 6(h) mm

1. Slide the lower baffle plate up and over the lower set of support hooks welded to the top of the firebox.
2. Slide the plate back so that it rests on the lower support rod on the rear wall of the firebox.
3. Unlike the upper baffle plate, the lower baffle plate rests on a slight angle sloping down and back to the rear of the firebox.

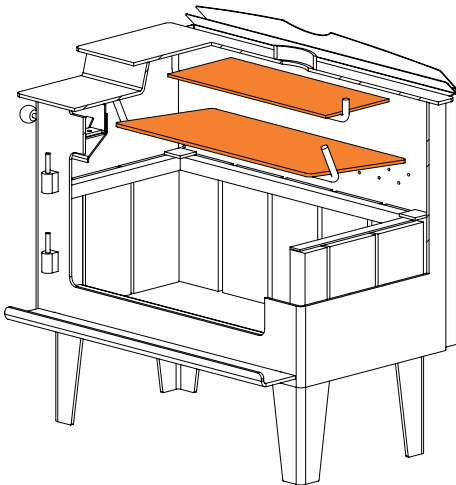

8. INSTALLING ASH PLATE

The ash plate acts to protect the front of the firebox below the door opening from the hot coal bed and fire.

When positioning the ash plate, ensure that the front top edge is flush against the inside edge of the firebox beneath the door opening.

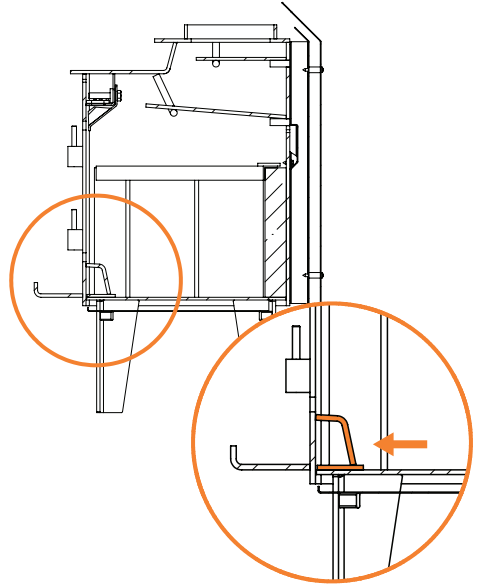

9. TECHNICAL DRAWINGS

9.1. MK1 LEGS

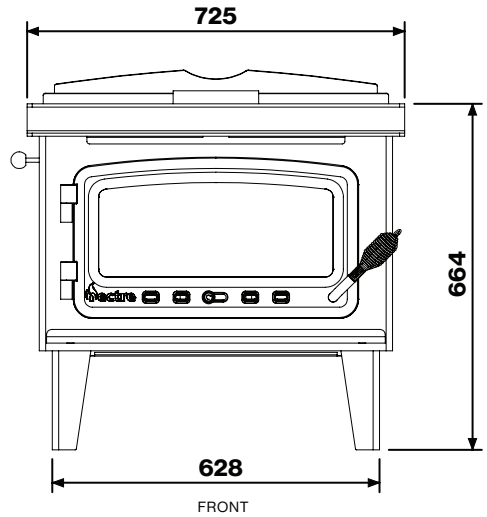
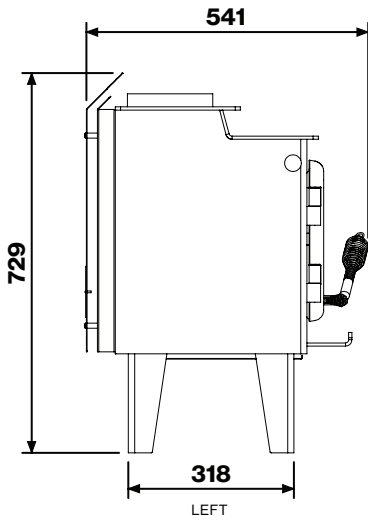
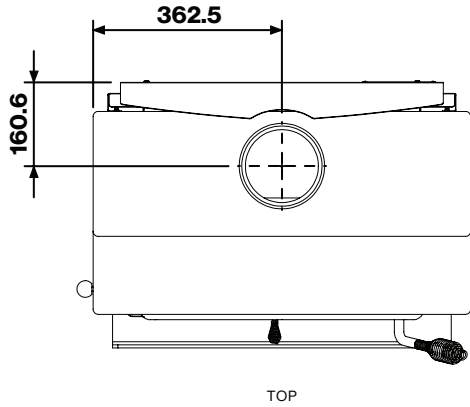

9.2. MK1 PEDESTAL

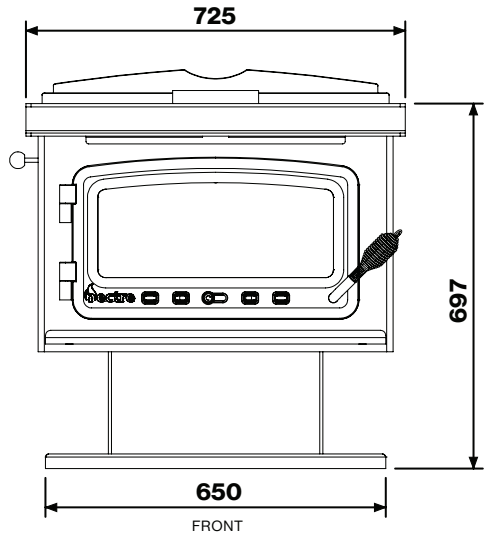
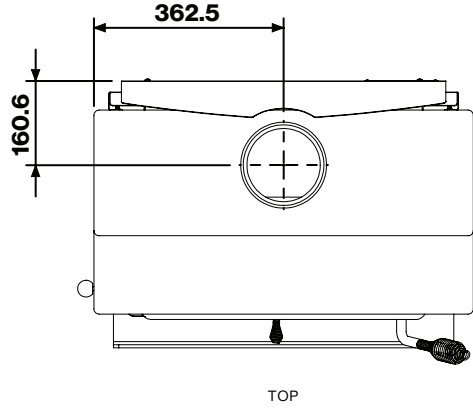
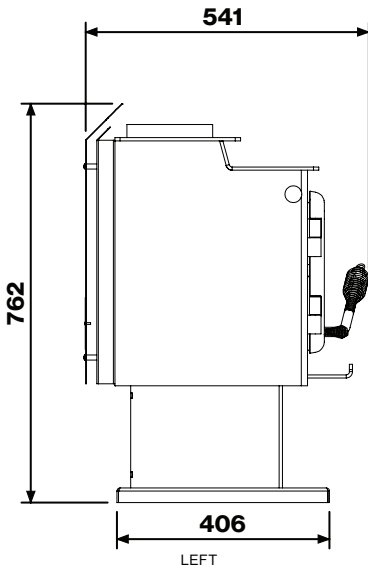



Glen Dimplex Australia Pty Ltd

8 Lakeview Drive,
Scoresby Victoria 3179
Australia

T: 1300 554 155

General & Sales Enquiries: flame.care@glendimplex.com.au

Technical Service: flame.support@glendimplex.com.au

www.glendimplex.com.au