



# Nectre MK1 LE

## Operating Instructions



Keep these instructions for future reference



Glen Dimplex Australia proudly supports the activities of Landcare Australia through its membership of the AHHA

## CONTENTS

1. OPERATING .....	1
1.1. IMPORTANT INFORMATION .....	1
1.2. GENERAL OPERATION .....	2
1.3. USING THE APPLIANCE FOR THE FIRST TIME .....	2
1.4. RECOMMENDED FUELS .....	2
1.5. LIGHTING THE FIRE .....	2
1.6. RUNNING THE APPLIANCE .....	3
1.7. BURNING TIPS .....	3
1.8. ASH REMOVAL .....	4
1.9. FLUE/CHIMNEY FIRE .....	4
1.10. CLEANING PAINT WORK AND GLASS .....	4
1.11. CLEANING THE FLUE .....	4
1.12. TROUBLESHOOTING TIPS .....	4
2. MAINTENANCE AND SERVICING .....	5
2.1. REPLACING THE FIRE BRICKS .....	5
2.2. REPLACING THE BRICK RETAINER .....	5
2.3. REPLACING THE BAFFLE PLATES .....	5
2.4. REPLACING THE ASH PLATE .....	6
2.5. ADJUSTING THE DOOR .....	6
2.6. REPLACING DOOR GLASS .....	6
2.7. REPLACING THE DOOR SEAL .....	6
2.8. REPLACEMENT SPARE PARTS LIST .....	7
3. WARRANTY .....	7

## 1. OPERATING

**THE OPERATING INSTRUCTIONS IN THIS MANUAL APPLY TO THE NECTRE MK1 LE WOOD HEATER MODELS.**

THEY HAVE BEEN TESTED FOR EMISSIONS AND EFFICIENCY AND COMPLY ACCORDING TO AS/NZS 4012 & AS/NZS 4013.

### 1.1. IMPORTANT INFORMATION

Before use of this appliance please read these instructions fully.

**WARNING: ANY MODIFICATION OF THE APPLIANCE THAT HAS NOT BEEN APPROVED IN WRITING BY THE TESTING AUTHORITY IS CONSIDERED AS BREACHING AS/NZS 4013.**

**WARNING: DO NOT USE FLAMMABLE LIQUIDS OR AEROSOLS TO START OR REKINDLE THE FIRE.**

**WARNING: DO NOT USE FLAMMABLE LIQUIDS OR AEROSOLS IN THE VICINITY OF THIS APPLIANCE WHEN IT IS OPERATING.**

**WARNING: DO NOT STORE FUEL WITHIN HEATER INSTALLATION CLEARANCES.**

**WARNING: WHEN OPERATING THIS APPLIANCE AS AN OPEN FIRE USE A FIRE SCREEN.**

**WARNING: OPEN AIR CONTROL (AND DAMPER WHEN FITTED) BEFORE OPENING FIRING DOOR.**

**WARNING: DO NOT BURN WOOD THAT IS PAINTED; OR IS COATED WITH PLASTIC; OR HAS BEEN TREATED WITH ANY CHEMICAL.**

**CAUTION: THIS APPLIANCE SHOULD NOT BE OPERATED WITH A CRACKED GLASS.**

**CAUTION: THIS APPLIANCE SHOULD BE MAINTAINED AND OPERATED AT ALL TIMES IN ACCORDANCE WITH THESE INSTRUCTIONS.**

The appliance or flue system should not be modified in any way without the written approval of the manufacturer.

Extractor fans or cooker hoods must not be placed in the same room or space as this can cause appliance to emit smoke into the room.

## 1.2. GENERAL OPERATION

### Air Controls

The top air slide allows air to enter the firebox from above the door where it is then drawn down into the base of the fire while keeping the glass clean. Pull knob out to the left to open and push in to the right to close.

The bottom air slide allows air to enter directly into the base of the fire and is used as a boost especially when getting the fire up to temperature. Slide spring handle to the left to open and to the right to close.

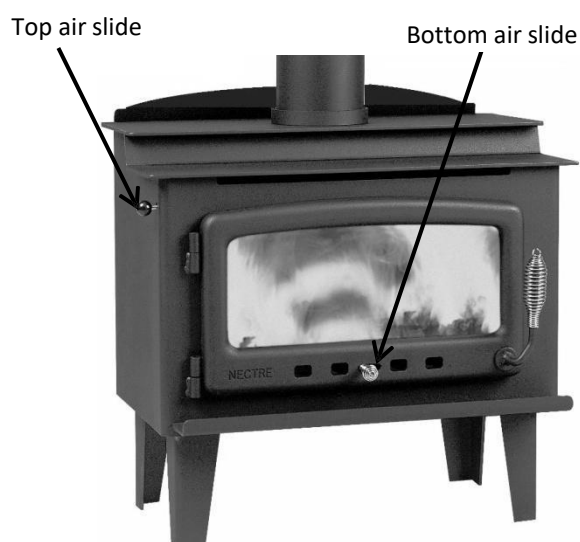

### Door Handle

**Warning:** The door handle may get hot if the appliance has been left in the high burn setting for an extended period. Use a protective glove to open.

Open the top air slide before opening the door to eliminate the chance of backdraft and smoke entering the room.

## 1.3. USING THE APPLIANCE FOR THE FIRST TIME

- For the first few times the appliance is lit, odorous fumes will be given off as the paint cures.
- Do not touch the paint work while it is curing otherwise it can leave a permanent mark on the appliance.
- Keep the room well ventilated until these fumes have cleared.
- Once the paint has cured, this will not re-occur.

## 1.4. RECOMMENDED FUELS

- Burn only seasoned hardwood timber with a moisture content of less than 20%.
- Newly cut wood should be split and allowed to dry/season for 12 to 18 months before use.
- Wood should be stored in an environment protected from the weather to minimise any potential moisture content.
- For best results, wood should not exceed  $\frac{3}{4}$  of the firebox front to back dimension in length and 150mm in diameter. Any larger and appliance will not operate at its optimum. It is better to burn several smaller pieces of wood than one large piece at a time.
- Poor quality timber:
  - Causes low combustion efficiency.
  - Produces poor emissions (smoky).
  - Results in additional build-up of creosote (soot) in the flue which will then require regular cleaning and may result in a flue fire.
- Do not burn painted, impregnated/treated wood, manufactured board products or pallet wood.

## 1.5. LIGHTING THE FIRE

- 1) Place firelighters or paper and dry kindling wood in the base of the firebox.
- 2) Fully open air controls (slide top and bottom air slides to the left).
- 3) Light the paper or firelighters.
- 4) Once the fire has taken hold add larger pieces of wood. For optimal burn conditions, place the logs in a front to back orientation (right angles to the door opening). Too many logs may smother the fire.
- 5) Once the fire is established, close the bottom air slide (slide to the right). Leaving this open once the fire has established can risk over-firing and damaging the appliance.

**Do not leave the appliance unattended while the door is open.**

**Do not leave fire unattended with bottom air control open as over-firing may occur.**

## 1.6. RUNNING THE APPLIANCE

### High Heat Output

This setting is not the most energy efficient as some heat is lost up the flue instead of being transferred into the room. However, once fire has established, particulate emissions will be very low (clean burning).

- After establishing the fire and loading it with larger pieces of wood, leave it running with the top air slide fully open to generate high heat output.
- Running the appliance with the door open will not produce maximum heating in the room as it will draw a lot of already warmed air out of the room.
- Similarly running the heater with the top air slide and the bottom air slide fully open will often not give the hottest fire as too much heat is lost up the flue and does not come into the room
- **Do not overload firebox with fuel.**

### Low Heat Output

This setting will provide the best energy efficiency as the wood burns for longer. However, if not operated correctly may result in higher particulate emissions.

- The heat output on the appliance can be reduced by closing the air controls which will restrict the oxygen supplied to the fire and slow down the rate at which the wood burns.
- **Prior to closing the air slide**, ensure the fire is burning briskly. This may require opening the air slide fully for 5-10mins before shutting down.
- For the optimum between clean burning, and getting the best in efficiency, from the fully closed position, open the top air slide 4-5mm. The bottom air slide must be shut.
- The top air slide can be adjusted to any position so desired depending on wanted heat output versus burn time.

### Reload with more wood

- 1) Open the top air slide before opening the door.
- 2) Rake / break up any existing coals.
- 3) Load wood with the length orientated front to back. Better results will be achieved by loading several smaller pieces of wood rather than one large piece.
- 4) Close the door with the top air slide fully open and leave for a minimum of 10 minutes to allow the fresh wood to catch.
- 5) After 10 or more minutes, the air slide can be adjusted to the desired heat output setting.

## 1.7. BURNING TIPS

### Fuel Quality

Use wood with a moisture content of less than 20%. Logs should not feel moist or have moss and fungal growths.

Symptoms of burning wet wood:

- Difficulty starting and keeping a fire burning well
- Smoke and only small flames
- Dirty glass and/or fire bricks
- Rapid creosote build-up in the flue/chimney
- Low heat output
- Short burn times, and blue/grey smoke from the flue/chimney outlet

If on the rare occasion the wood is not ideally seasoned, still retaining some moisture, continue using the top air slide to determine the heat output and burn rate but also leave the bottom air slide open 3-4mm. This will allow some extra oxygen into the base of the fire allowing it to burn hotter.

Run appliance at high heat output for a short period each day to avoid large build-up of tars and creosote within the appliance and flue.

### Flue Draught

The flue has two main functions:

- 1) To safely remove smoke, gases and fumes from the appliance.
- 2) To provide sufficient draught (suction) in the appliance to ensure the fire keeps burning.

Draught is caused by the rising hot air in the flue when the fire has been lit.

The position, height and size of the flue can affect the performance of the flue draught. Refer to installation guide for details on flue installation.

Factors affecting the flue draught include:

- Insufficient flue height
- Trees or other buildings nearby causing turbulence
- High and gusty winds
- Outside temperature and weather conditions
- Blocked flue

For advice on the correction of persistent flue problems consult your supplier/installer for more detail.

## 1.8. ASH REMOVAL

Depending on the type of wood burnt and frequency, the ashes will need removing every 2 to 6 weeks.

Leave a 10mm layer of ash to insulate the firebox bottom.

Excess ashes should be removed when necessary, placed in a non-combustible container with a tightly fitting lid and moved outdoors immediately to a location clear of combustible materials.

## 1.9. FLUE/CHIMNEY FIRE

If a flue/chimney fire occurs:

- Shut air controls fully to smother the fire.
- Do not use the appliance after a flue fire until an accredited installer has assessed the cause and any resultant damage.

## 1.10. CLEANING PAINT WORK AND GLASS

- The appliance, when cool, can be cleaned with a damp cloth.
- Over the years, the black paint will fade and can be touched up with Stove Bright metallic black paint.
- To clean the glass, we recommend using a household window cleaner or general purpose cleaner with a soft cloth.

**Do not use abrasive cleaner or scourer pads.**

## 1.11. CLEANING THE FLUE

Check inside of flue prior to each season for any build-up of creosote (wood tar).

To check the flue:

- 1) Remove the baffle plates (refer to 'Replacing the Baffle Plates' under Maintenance & Servicing).
- 2) Hold a small mirror on an angle below the flue, with a torch shining towards it, and look for black creosote build-up. It is normal to see a fine black powdery layer, but if built up layers of creosote can be seen, the flue requires cleaning.
- 3) If no cleaning is required, re-fit the baffle plate.

To clean the flue:

- 1) A flue cleaning brush can be purchased from most wood heater retail outlets or large hardware stores. Alternatively, hire a flue cleaning service to do the job for you (it's a dirty job).
- 2) With the baffle plates removed, tie a rope to one end of the brush, and drop the rope down the flue (from outside on top of the roof).

- 3) Grab the end of the rope from inside the firebox and pull the brush down through the flue.
- 4) Check the inside of the flue with the mirror and torch.
- 5) Repeat cleaning process if necessary.
- 6) Once the flue is clean, remove any excess creosote from the firebox.
- 7) Replace the baffle plate.

**Only pull brush downwards through flue, as pulling upwards may separate the flue sections at their joins.**

## 1.12. TROUBLESHOOTING TIPS

### Glass in door blackening

This can have several possible causes:

- Burning unseasoned wood — If the wood is too wet, it will cause the glass to blacken.
- Appliance operated at low temperature — After an overnight burn where the air control has been fully closed, the glass may have blackened. When the fire is restoked and burning on the high heat setting, the blackened glass should self-clean.
- Problems with the flue — Insufficient flue draught can cause the glass to blacken. If the flue is too short, not properly insulated, or in a position that results in a downdraught, then there will be insufficient flue draught. Contact the installer should this happen.

### Trouble starting the fire

When cleaning, it is best to retain some ash in the base of the firebox. A layer of ash insulates the base, helping to maintain a high temperature for combustion. Also, if all the ash has been removed from the firebox, it can affect the supply of air to the base of the fire.

## 2. MAINTENANCE AND SERVICING

### 2.1. REPLACING THE FIRE BRICKS

The firebox needs fire bricks to increase the thermal mass and guarantee the longevity of the steel firebox. Over time the firebricks may become cracked and crumble away. At this point they should be replaced.

To replace the firebricks:

- 1) Raise the brick retainer
- 2) Remove bricks and ash from the fire box.
- 3) Replace with new bricks and lower the brick retainer over the bricks.

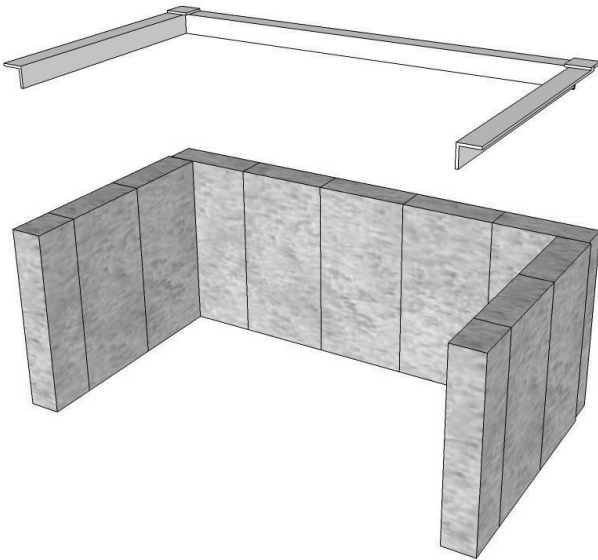

### 2.2. REPLACING THE BRICK RETAINER

The brick retainer holds the bricks in place. Over time, the brick retainer may warp or burn through, and should be replaced.

- 1) Remove the side and rear fire bricks before fitting the brick retainer.
- 2) With the retainer orientated with the arms pointing up (like a square 'U' shape), push one end into the back corner of the firebox.
- 3) With the retainer in a diagonal orientation relative to the firebox, tilt the top slightly forward allowing the bottom corner to drop into the firebox at the front.
- 4) Push the bottom front corner towards the back of the firebox allowing the top of the arm to enter the firebox.
- 5) Continue pushing the bottom corner towards rear of firebox so that retainer sits flat in the firebox.
- 6) Raise the retainer and re-install the fire bricks.

### 2.3. REPLACING THE BAFFLE PLATES

The baffle plates help to retain the heat in the firebox by lengthening the path of the flame before it goes up the flue.

Over time, the baffle plates will begin to sag a little due to the excessive heat. This will not affect the way the fire burns.

Eventually the baffle plates will burn through (5+ years) and must be replaced.

To remove the baffle plates:

- 1) Slide the lower baffle plate forward so that it can be lowered at the back.
- 2) Lowering the rear of the baffle will allow the front to slide past the front support pins.
- 3) Once the baffle has cleared the front support pins, it can be removed from the firebox.
- 4) Remove the upper baffle plate in the same way.
- 5) Repeat steps 1) to 4) in reverse to fit the new baffle plate (see image below for correct baffle placement).

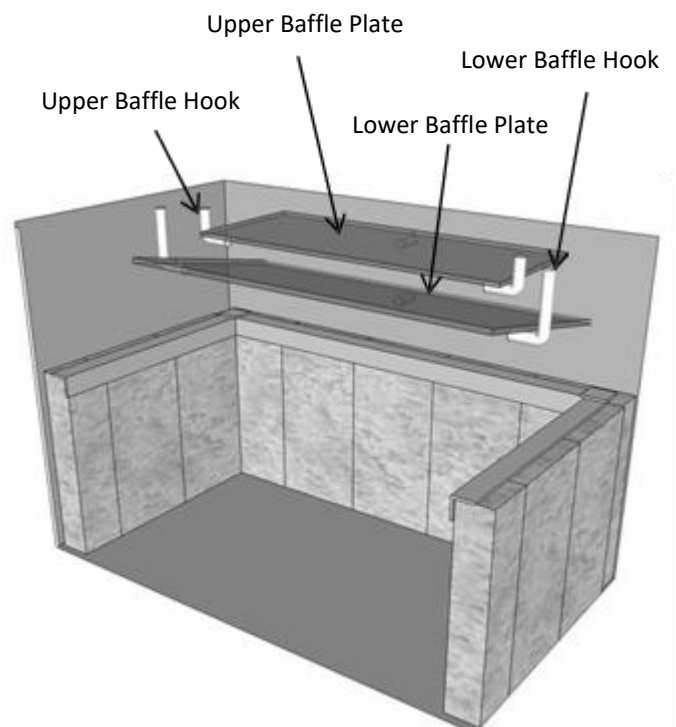



## 2.4. REPLACING THE ASH PLATE

The ash plate acts to protect the front of the firebox below the door opening from the hot coal bed and fire.

Over time, this may burn through in which case it should be replaced to ensure the longevity of the firebox.

Clear ash away from the base of the ash plate. Remove the old ash plate and replace with a new one. When positioning the new ash plate, ensure that the front top edge is flush against the inside edge of the firebox beneath the door

## 2.5. ADJUSTING THE DOOR

If the door does not close firmly, the latch can be adjusted.

The latch is fastened onto the door with two removable washers. Use a socket wrench to undo the M12 nut, then remove one of the washers directly beneath the nut. Securely fasten latch assembly again.

Close the door with the door handle to test for any improvement. If no improvement, remove second washer.

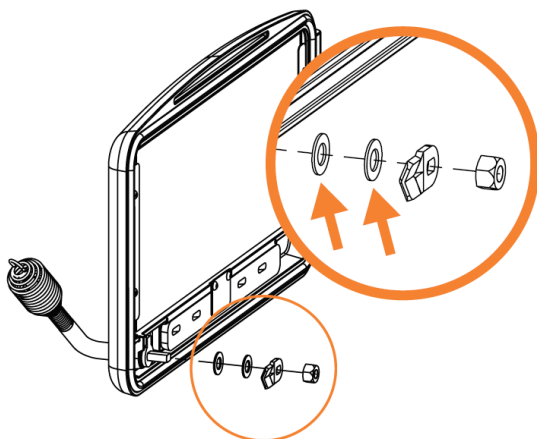

## 2.6. REPLACING DOOR GLASS

This task may be easier with the door removed from the appliance and laid horizontally on a work-bench.

To replace the door glass:

- 1) Two stainless steel strips hold the glass in place. Remove the four screws from the stainless steel strips with a 3mm hex key.

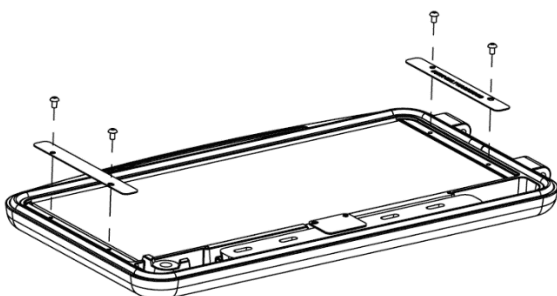

- 2) Take out the glass, and check if the grey rope beneath needs replacing. If so, replace this rope as well.

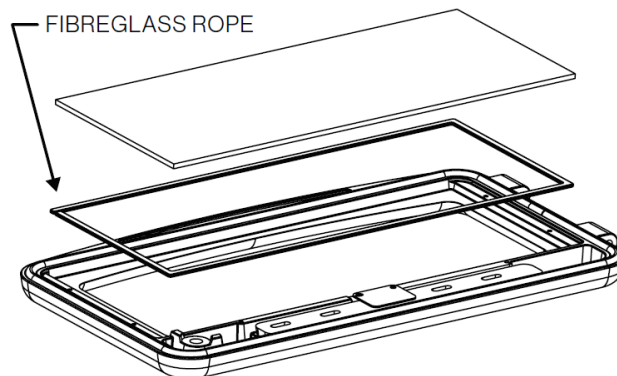

- 3) Position the new glass on top of the grey rope and re-fit the stainless steel strips and screws.
- 4) Take extra care not to over-tighten the screws, otherwise the glass will crack when the heater gets hot and the door expands.
- 5) Dispose of the old glass in a responsible manner.

## 2.7. REPLACING THE DOOR SEAL

This task may be easier with the door removed from the appliance and laid horizontally on a work-bench.

- 1) Remove any remains of the old seal from the door.
- 2) Clean out the groove in the door that the seal was bedded in, using a flat head screw driver or equivalent.
- 3) Run a thin bead of clear roof and gutter silicone along the groove.
- 4) Starting at one end, press the new door seal into the groove on the door.
- 5) Refit the door if it has been removed.



## 2.8. REPLACEMENT SPARE PARTS LIST

### Firebricks

9 @ 230mm x 115mm x 38mm

2 @ 230mm x 55mm x 38mm

### Brick Retainer

Steel 420mm x 345mm

### Upper Baffle Plate

Steel 400mm x 160mm x 5mm

### Lower Baffle Plate

Steel 495mm x 250mm x 6mm

### Ash Plate

Steel 500mm x 60mm x 50mm

### Door Seal

1610mm x 13mm round braided ceramic rope

### Glass Seal

1360mm x 8mm x 3mm flat adhesive back

### Door Glass

476mm x 200mm x 5mm pyro ceramic

## 3. WARRANTY

Glen Dimplex Australia Pty. Ltd. warrants this stove to be able to operate under normal use and service and within 10 years from the date of the original purchase on the terms herein shall repair or replace without cost to the original customer any part thereof which shall be returned to our factory, transportation charges prepaid and which our inspection shows would prevent operation.

This warranty does not apply to firebricks, brick retainer, baffle, door seal, glass, any electrical components, nor discolouration of the surface or tarnishing of chrome fittings all of which require normal service to maintain them.

Under the terms of this warranty, Glen Dimplex Australia Pty. Ltd. assumes no responsibility for the labour costs involved in removing or replacing the stove. Nor shall Glen Dimplex Australia Pty. Ltd. be liable for any injury, loss, or damage (direct, indirect or consequential) arising out of the use or inability to use the product, or its removal and replacement. All other stove warranties, expressed or implied are excluded to the extent possible to law. Any claims against Glen Dimplex Australia Pty. Ltd. must be brought within Australian Jurisdiction.

The Retailer does not have the authority to alter this warranty.



Glen Dimplex  
AUSTRALIA

Glen Dimplex Australia Pty Ltd

1340 Ferntree Gully Road,  
Scoresby Victoria 3179  
Australia

T: 1300 556 816 | F: 1800 058 900

Email: [sales@glendimplex.com.au](mailto:sales@glendimplex.com.au)